

Contents

HP E1333A 3-Channel Universal Counter User's Manual
Edition 3

[Click here to return to HP TS-5400 Systems On-Line Manuals Main Contents](#)

Warranty	5
WARNINGS	6
Safety Symbols	6
Declaration of Conformity	7
Reader Comment Sheet	9
Chapter 1. Getting Started with the HP E1333A	11
Using This Chapter	11
Universal Counter Description	11
Channel Descriptions	13
Instrument Definition	13
Programming the Universal Counter	14
Selecting SCPI Commands	14
Chapter 2. Configuring the HP E1333A Universal Counter	15
Using This Chapter	15
Warnings and Cautions	15
Connecting Field Cables	15
Configuring the Universal Counter	16
Setting the Address Switch	16
VXIbus Interrupt Lines	17
Interrupt Priority	17
Chapter 3. Using the HP E1333A Universal Counter	19
Using This Chapter	19
Default Conditions	20
Input Signal Constraints	21
Measurement Procedure	21
Setting Input Signal Conditioning	22
Measurement Examples	24
Totalizing Events	25
Example: Counting Events	25
Frequency Measurement	27
Example: Making a Frequency Measurement	27
Ratio Measurement	29
Example: Making a Ratio Measurement	29
Period Average Measurement	31
Example: Making a Period Average Measurement	31

Pulse Width Measurement	32
Example: Making a Pulse Width Measurement	32
Time Interval Measurement	34
Example: Making a Time Interval Measurement	34
Chapter 4. Understanding the HP E1333A Universal Counter	37
Using This Chapter	37
Counter Configuration	37
Measurement Procedure	39
Selecting Input Parameters	40
Input Signal Conditioning	40
Event Slope and Event Level	41
Measurement Functions	42
MEASure, CONFigure, and SENSE:FUNctioN	44
INITiate, READ?, and FETCh?	45
Stopping a Measurement	46
Selecting Range and Resolution	46
Range (expected value)	46
Resolution	47
Setting the Range and Resolution	47
Selecting Aperture Time and Number of Periods	47
Aperture Time (Gate Time)	48
Number of Periods	49
Selecting Trigger Source	50
Trigger System Commands	51
Synchronizing Instruments	52
Synchronizing the Counter with a Computer	52
Checking for Errors	53
Checking for Overflow	54
Checking for Overflow Using an Interrupt	55
Querying the Counter	56
Chapter 5. HP E1333A Universal Counter Command Reference	57
Using This Chapter	57
Command Types	57
Common Command Format	57
SCPI Command Format	57
Linking Commands	59
SCPI Command Reference	60
ABORt	60
CONFigure	61
:FREQuency	62
:NWIDth	63
:PERiod	64
:PWIDth	65
:RATio	66
:TINTerval	67
:TOTalize	68

CONFigure?	69
DISPlay	70
:MONitor:CHANnel	70
:MONitor:CHANnel?	70
:MONitor[:STATe]	71
:MONitor[:STATe]?	71
FETCh?	72
INITiate	73
INPut	74
:ATTenuation	74
:ATTenuation?	75
:COUpling	75
:COUpling?	75
:FILTer[:LPASs] [:STATe]	75
:FILTer[:LPASs] [:STATe]?	76
:IMPedance	76
:IMPedance?	76
MEASure	77
:FREQuency?	78
:NWIDth?	79
:PERiod?	80
:PWIDth?	81
:RATio?	82
:TINTerval?	83
READ?	84
[SENSe:]	85
EVENT:LEVel	86
EVENT:LEVel?	86
EVENT:SLOPe	87
EVENT:SLOPe?	87
FREQuency :APERture	87
FREQuency :APERture?	88
FUNction	89
FUNction?	90
PERiod:NPERiods	91
PERiod:NPERiods?	92
RATio:NPERiods	92
RATio:NPERiods?	93
TINTerval:NPERiods	93
TINTerval:NPERiods?	94
STATus	95
:QUEStionable	96
:QUEStionable :CONDition?	96
:QUEStionable :ENABle	96
:QUEStionable :ENABle?	97
:QUEStionable [:EVENT]?	97
SYSTem	98
:ERRor?	98

TRIGger	99
[:IMMEDIATE]	99
:SOURce	99
:SOURce?	100
IEEE 488.2 Common Commands	101
Command Quick Reference	102
Appendix A. HP E1333A Specifications	105
Appendix B. HP E1333A Universal Counter Register-Based Programming	107
Using This Appendix	107
About Register-Based Programming	107
Addressing the Registers	107
The Base Address	108
Register Offset	109
Register Definitions	111
Register Descriptions	111
Manufacturer ID Register	111
Device Type Register	112
Status (READ)/Control (WRITE) Register	112
Command (WRITE)/ Response (READ) Register	113
Command List	113
Parameter Register	114
Interrupt Vector Register	114
Interrupt Requests	114
Command Summary	115
Register Command 1	115
Register Command 2	115
Register Command 3	115
Register Command 4	116
Register Command 5	116
Register Command 6	116
Register Command 10	117
Register Command 12	118
Register Command 13	118
Register Command 14	120
Register Command 15	120
Register Programming Procedure	120
Computing the Answer	122
Register Programming Flowchart	124
Programming Examples	125
Resetting the Counter	125
Reading the ID, Device Type, and Status Registers	127
Making Measurements with the Counter	129
Embedded Controller Example Programs	131
Appendix C. HP E1333A Universal Counter Error Messages	139

Certification

Hewlett-Packard Company certifies that this product met its published specifications at the time of shipment from the factory. Hewlett-Packard further certifies that its calibration measurements are traceable to the United States National Institute of Standards and Technology (formerly National Bureau of Standards), to the extent allowed by that organization's calibration facility, and to the calibration facilities of other International Standards Organization members.

Warranty

This Hewlett-Packard product is warranted against defects in materials and workmanship for a period of three years from date of shipment. Duration and conditions of warranty for this product may be superseded when the product is integrated into (becomes a part of) other HP products. During the warranty period, Hewlett-Packard Company will, at its option, either repair or replace products which prove to be defective.

For warranty service or repair, this product must be returned to a service facility designated by Hewlett-Packard (HP). Buyer shall prepay shipping charges to HP and HP shall pay shipping charges to return the product to Buyer. However, Buyer shall pay all shipping charges, duties, and taxes for products returned to HP from another country.

HP warrants that its software and firmware designated by HP for use with a product will execute its programming instructions when properly installed on that product. HP does not warrant that the operation of the product, or software, or firmware will be uninterrupted or error free.

Limitation Of Warranty

The foregoing warranty shall not apply to defects resulting from improper or inadequate maintenance by Buyer, Buyer-supplied products or interfacing, unauthorized modification or misuse, operation outside of the environmental specifications for the product, or improper site preparation or maintenance.

The design and implementation of any circuit on this product is the sole responsibility of the Buyer. HP does not warrant the Buyer's circuitry or malfunctions of HP products that result from the Buyer's circuitry. In addition, HP does not warrant any damage that occurs as a result of the Buyer's circuit or any defects that result from Buyer-supplied products.

NO OTHER WARRANTY IS EXPRESSED OR IMPLIED. HP SPECIFICALLY DISCLAIMS THE IMPLIED WARRANTIES OF MERCHANTABILITY AND FITNESS FOR A PARTICULAR PURPOSE.

Exclusive Remedies

THE REMEDIES PROVIDED HEREIN ARE BUYER'S SOLE AND EXCLUSIVE REMEDIES. HP SHALL NOT BE LIABLE FOR ANY DIRECT, INDIRECT, SPECIAL, INCIDENTAL, OR CONSEQUENTIAL DAMAGES, WHETHER BASED ON CONTRACT, TORT, OR ANY OTHER LEGAL THEORY.

Notice

The information contained in this document is subject to change without notice. HEWLETT-PACKARD (HP) MAKES NO WARRANTY OF ANY KIND WITH REGARD TO THIS MATERIAL, INCLUDING, BUT NOT LIMITED TO, THE IMPLIED WARRANTIES OF MERCHANTABILITY AND FITNESS FOR A PARTICULAR PURPOSE. HP shall not be liable for errors contained herein or for incidental or consequential damages in connection with the furnishing, performance or use of this material. This document contains proprietary information which is protected by copyright. All rights are reserved. No part of this document may be photocopied, reproduced, or translated to another language without the prior written consent of Hewlett-Packard Company. HP assumes no responsibility for the use or reliability of its software on equipment that is not furnished by HP.

Restricted Rights Legend

Use, duplication or disclosure by the U.S. Government is subject to restrictions as set forth in subparagraph (c)(1)(ii) of the Rights in Technical Data and Computer Software clause in DFARS 252.227-7013.

Hewlett-Packard Company
3000 Hanover Street
Palo Alto, California 94304 U.S.A.

Rights for non-DOD U.S. Government Departments and Agencies are as set forth in FAR 52.227-19 (c) (1,2).



HP E1333A 3-Channel Universal Counter Module User's Manual
Edition 3
Copyright © 1995 Hewlett-Packard Company. All Rights Reserved.

Documentation History

All Editions and Updates of this manual and their creation date are listed below. The first Edition of the manual is Edition 1. The Edition number increments by 1 whenever the manual is revised. Updates, which are issued between Editions, contain replacement pages to correct or add additional information to the current Edition of the manual. Whenever a new Edition is created, it will contain all of the Update information for the previous Edition. Each new Edition or Update also includes a revised copy of this documentation history page.

Edition 1	September 1989
Update 1	October 1990
Edition 2	October 1993
Edition 3	July 1995

Safety Symbols



Instruction manual symbol affixed to product. Indicates that the user must refer to the manual for specific WARNING or CAUTION information to avoid personal injury or damage to the product.



Alternating current (AC).



Direct current (DC).

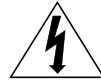

Indicates hazardous voltages.



Indicates the field wiring terminal that must be connected to earth ground before operating the equipment—protects against electrical shock in case of fault.

WARNING

Calls attention to a procedure, practice, or condition that could cause bodily injury or death.

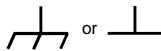

Frame or chassis ground terminal—typically connects to the equipment's metal frame.

CAUTION

Calls attention to a procedure, practice, or condition that could possibly cause damage to equipment or permanent loss of data.

WARNINGS

The following general safety precautions must be observed during all phases of operation, service, and repair of this product. Failure to comply with these precautions or with specific warnings elsewhere in this manual violates safety standards of design, manufacture, and intended use of the product. Hewlett-Packard Company assumes no liability for the customer's failure to comply with these requirements.

Ground the equipment: For Safety Class 1 equipment (equipment having a protective earth terminal), an uninterruptible safety earth ground must be provided from the mains power source to the product input wiring terminals or supplied power cable.

DO NOT operate the product in an explosive atmosphere or in the presence of flammable gases or fumes.

For continued protection against fire, replace the line fuse(s) only with fuse(s) of the same voltage and current rating and type. DO NOT use repaired fuses or short-circuited fuse holders.

Keep away from live circuits: Operating personnel must not remove equipment covers or shields. Procedures involving the removal of covers or shields are for use by service-trained personnel only. Under certain conditions, dangerous voltages may exist even with the equipment switched off. To avoid dangerous electrical shock, DO NOT perform procedures involving cover or shield removal unless you are qualified to do so.

DO NOT operate damaged equipment: Whenever it is possible that the safety protection features built into this product have been impaired, either through physical damage, excessive moisture, or any other reason, REMOVE POWER and do not use the product until safe operation can be verified by service-trained personnel. If necessary, return the product to a Hewlett-Packard Sales and Service Office for service and repair to ensure that safety features are maintained.

DO NOT service or adjust alone: Do not attempt internal service or adjustment unless another person, capable of rendering first aid and resuscitation, is present.

DO NOT substitute parts or modify equipment: Because of the danger of introducing additional hazards, do not install substitute parts or perform any unauthorized modification to the product. Return the product to a Hewlett-Packard Sales and Service Office for service and repair to ensure that safety features are maintained.

Declaration of Conformity
according to ISO/IEC Guide 22 and EN 45014

Manufacturer's Name: Hewlett-Packard Company
Loveland Manufacturing Center

Manufacturer's Address: 815 14th Street S.W.
Loveland, Colorado 80537

declares, that the product:

Product Name: 3-Channel Universal Counter Module

Model Number: E1333A

Product Options: All

conforms to the following Product Specifications:

Safety: IEC 1010-1 (1990) Incl. Amend 1 (1992)/EN61010-1 (1993)
CSA C22.2 #1010.1 (1992)
UL 1244

EMC: CISPR 11:1990/EN55011 (1991): Group1 Class A
IEC 801-2:1991/EN50082-1 (1992): 4kVCD, 8kVAD
IEC 801-3:1984/EN50082-1 (1992): 3 V/m
IEC 801-4:1988/EN50082-1 (1992): 1kV Power Line

Supplementary Information: The product herewith complies with the requirements of the Low Voltage Directive 73/23/EEC and the EMC Directive 89/336/EEC and carries the CE-marking accordingly.

Tested in a typical configuration in an HP B-Size VXI mainframe.

May 20, 1995

Jim White, QA Manager

European contact: Your local Hewlett-Packard Sales and Service Office or Hewlett-Packard GmbH, Department HQ-TRE, Herrenberger Straße 130, D-71034 Böblingen, Germany (FAX +49-7031-14-3143).

Notes

Please fold and tape for mailing

Reader Comment Sheet

HP E1333A 3-Channel Universal Counter Module User's Manual
Edition 3

You can help us improve our manuals by sharing your comments and suggestions. **In appreciation of your time, we will enter you in a quarterly drawing for a Hewlett-Packard Palmtop Personal Computer** (U.S. government employees are not eligible for the drawing).

_____ Your Name	_____ City, State/Province
_____ Company Name	_____ Country
_____ Job Title	_____ Zip/Postal Code
_____ Address	_____ Telephone Number with Area Code

Please list the system controller, operating system, programming language, and plug-in modules you are using.

fold here

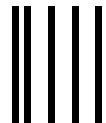

NO POSTAGE
NECESSARY
IF MAILED
IN THE
UNITED STATES



POSTAGE WILL BE PAID BY ADDRESSEE

HEWLETT-PACKARD COMPANY
Measurement Systems Division
Learning Products Department
P.O. Box 301
Loveland, CO 80539-9984

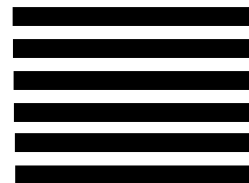

cut along this line



fold here

Please pencil-in one circle for each statement below:

- The documentation is well organized.
- Instructions are easy to understand.
- The documentation is clearly written.
- Examples are clear and useful.
- Illustrations are clear and helpful.
- The documentation meets my overall expectations.

Disagree	←————→					Agree
<input type="radio"/>	<input type="radio"/>	<input type="radio"/>	<input type="radio"/>	<input type="radio"/>	<input type="radio"/>	<input type="radio"/>
<input type="radio"/>	<input type="radio"/>	<input type="radio"/>	<input type="radio"/>	<input type="radio"/>	<input type="radio"/>	<input type="radio"/>
<input type="radio"/>	<input type="radio"/>	<input type="radio"/>	<input type="radio"/>	<input type="radio"/>	<input type="radio"/>	<input type="radio"/>
<input type="radio"/>	<input type="radio"/>	<input type="radio"/>	<input type="radio"/>	<input type="radio"/>	<input type="radio"/>	<input type="radio"/>
<input type="radio"/>	<input type="radio"/>	<input type="radio"/>	<input type="radio"/>	<input type="radio"/>	<input type="radio"/>	<input type="radio"/>

Please write any comments or suggestions below--be specific.

Chapter 1

Getting Started with the HP E1333A

Using This Chapter

This chapter describes the HP E1333A Universal Counter module. It also contains information on how to program the Counter using SCPI (Standard Commands for Programmable Instruments) commands. This chapter contains the following sections:

- Universal Counter Description Page 11
- Instrument Definition Page 13
- Programming the Universal Counter Page 14

Universal Counter Description

Refer to Figure 1-1 for the description of the Universal Counter module. The Universal Counter is a 3-channel counter capable of making frequency measurements, time interval measurements, ratio measurements, and counting up to 2^{32} (4.3 billion) operator defined events. Frequency can be measured up to 100 MHz on channels 1 and 2 and up to 1 GHz on channel 3. Time interval and ratio measurements require the use of the channel 1-channel 2 pair. The basic measurement functions of each channel are listed in Table 1-1.

Table 1-1. Channel Measurement Functions

Channel 1	Channel 2	Channel 3
Frequency	Frequency	Frequency
Period Average	Period Average	
Pulse Width	Pulse Width	
Time Interval	Time Interval	
Ratio	Ratio	
Totalize	Totalize	

The Counter can measure on one channel at any given time except it can count events simultaneously on channels 1 and 2 with the totalize function.

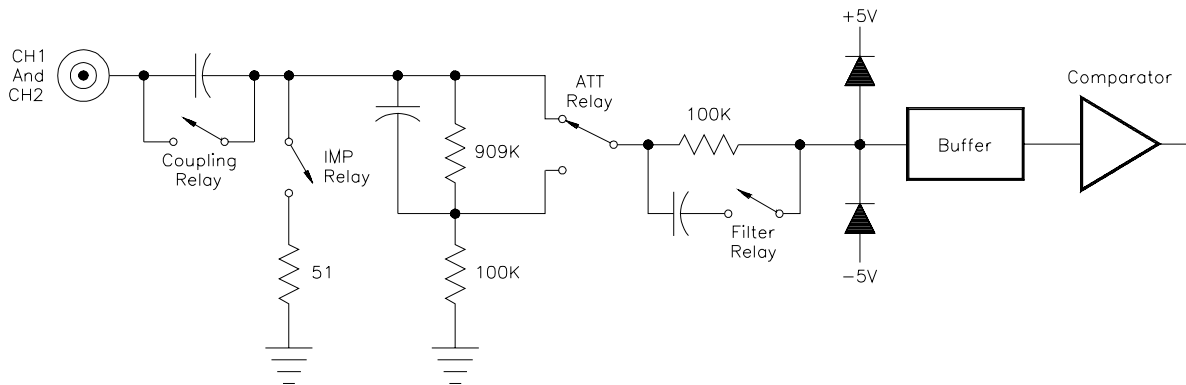
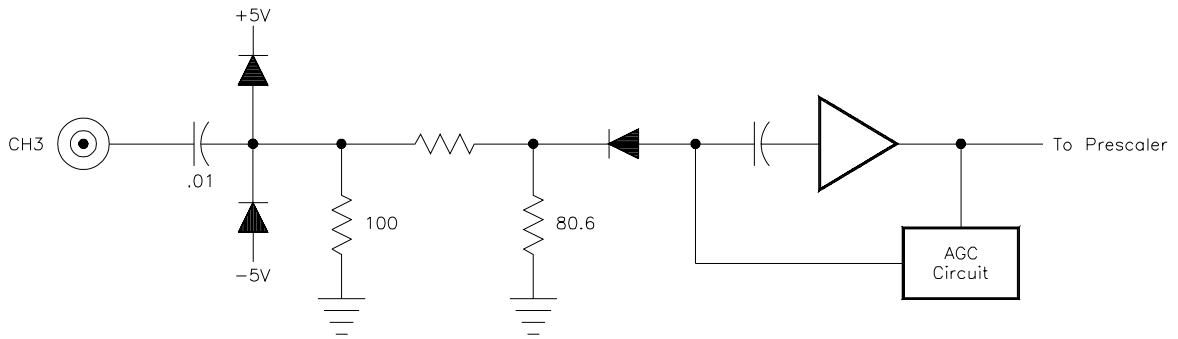
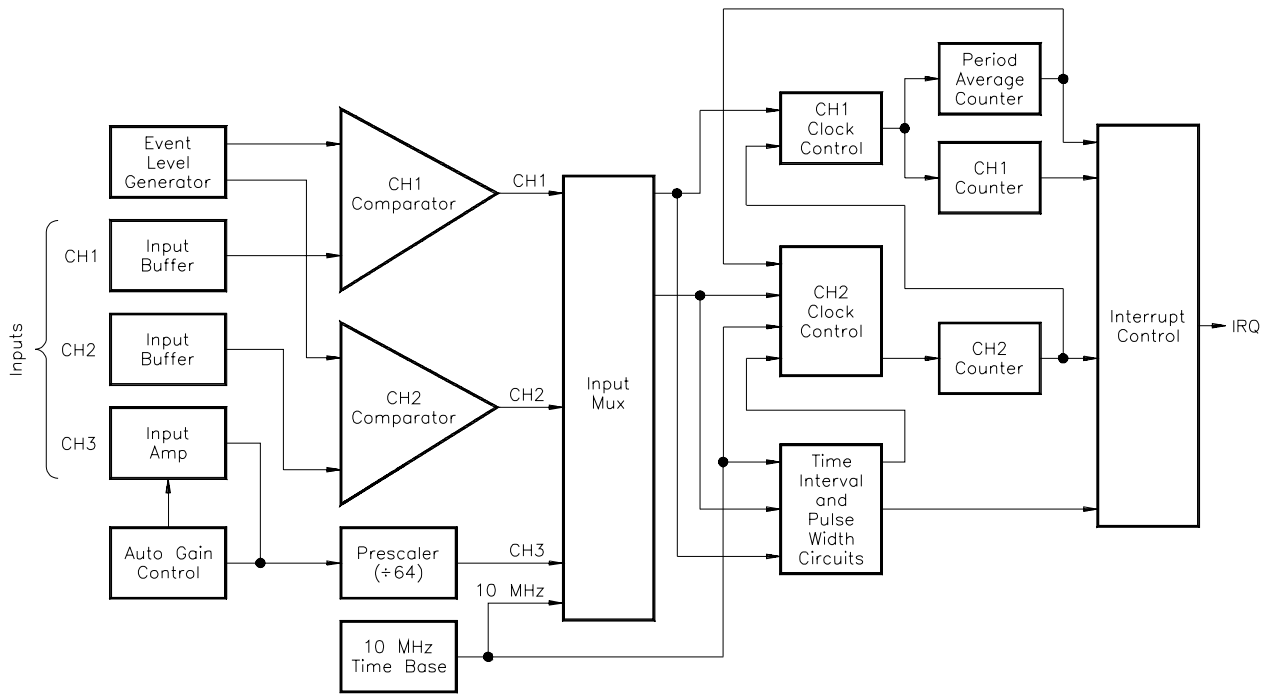

Figure 1-1. Universal Counter Block Diagram

Channel Descriptions

Each channel has an input terminal that must be physically connected to the input source. The measurement channel is then selected using a SCPI command. Channels 1 and 2 have programmable input characteristics. Channel 3 has fixed input characteristics not affected by changes to channels 1 and 2. Channel 3 is capable of measuring frequency only and extends the frequency measurement range to 1 GHz. Table 1-2 summarizes the input characteristics for channels 1, 2, and 3.

Table 1-2. Channel Input Characteristics

PARAMETER	CHANNEL 1 & 2	CHANNEL 3
Frequency Range	DC to 100 MHz	75 MHz to 1 GHz
Input Characteristics Range 1. Normal 2. /10 Impedance Coupling LP Filter	Normal or /10 ± 5V ± 42V 1MΩ or 50Ω AC or DC approx. 100 kHz	± 5V – 50Ω AC –
Event Level normal range /10 range	– 2.56 to + 2.54V – 25.6 to + 25.4V	0 V –

CAUTION

Damage to input circuits can result if input levels exceed 5 Vrms when the input impedance is 50Ω (>0.5 W). In general, any input will be damaged if the input voltage exceeds 42V or the input power exceeds 0.5W.

Instrument Definition

HP plug-in modules installed in an HP mainframe are treated as independent instruments each having a unique secondary HP-IB address. Each instrument is also assigned a dedicated error queue, input and output buffers, status registers and, if applicable, dedicated mainframe/command module memory space for readings or data. An instrument may be composed of a single plug-in module (such as a counter) or multiple plug-in modules (for a multiplexer or scanning multimeter).

Programming the Universal Counter

To program the Universal Counter using Standard Commands for Programmable Instruments (SCPI), you must select the controller language, interface address, and SCPI commands to be used. See the *HP 75000 Series B Installation and Getting Started Guide* for interface addressing and controller language information.

Selecting SCPI Commands

A SCPI command consists of a keyword, such as the CONFigure command CONF n :TOT, where n defines the channel to be configured. Most keywords require that you specify the channel (1, 2, or 3) you want to act on. The command defaults to channel 1 if a channel number is not specified. Some keywords must be followed by a parameter to make a specific selection. For example, input coupling is "INP:COUP DC", and "DC" sets the input coupling to DC coupling.

SCPI commands for the Universal Counter are presented in detail in Chapter 5.

Chapter 2

Configuring the HP E1333A Universal Counter

Using This Chapter

This chapter shows how to configure and connect field cables to the counter. This chapter contains the following sections:

- Warnings and Cautions Page 15
- Connecting Field Cables Page 15
- Configuring the Universal Counter Page 16

Warnings and Cautions

SHOCK HAZARD. Only service-trained personnel who are aware of the hazards involved should install, remove, or configure the Universal Counter module. Before you touch any installed module, disconnect hazardous voltages (including AC power) and all field wiring from the mainframe.

MAXIMUM VOLTAGE. The maximum voltage that may be applied to any BNC connector is 42V for the 1 M Ω input impedance (channels 1 and 2) and 5V for the 50 Ω input impedance (channels 1, 2, and 3). In general, the limiting factor is the maximum power which cannot exceed 0.5W.

STATIC ELECTRICITY. Static electricity is a major cause of component failure. To prevent damage to the electrical components in the counter module, observe anti-static techniques whenever removing a module from the mainframe or whenever working on a module.

Connecting Field Cables

Figure 2-1 shows the HP E1333A module front panel. The three input channels use BNC connectors for connecting the field cables.

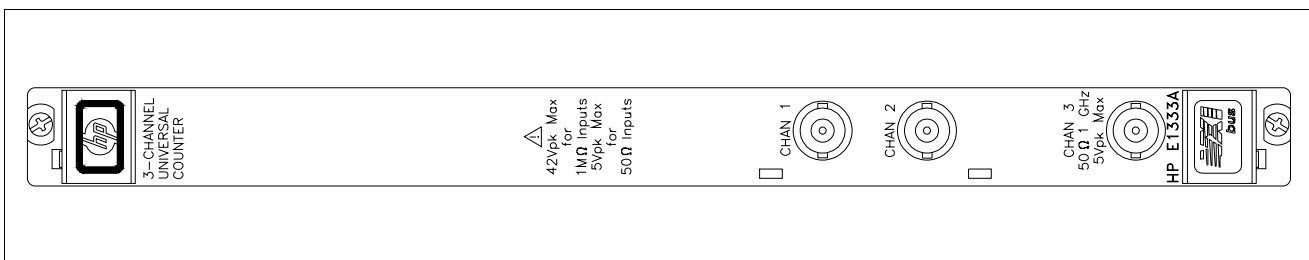

Figure 2-1. HP E1333A Universal Counter Front Panel

Configuring the Universal Counter

Configuring the Universal Counter module consists of:

- Setting the address switch
- Selecting the interrupt priority

Setting the Address Switch

The address switch (LADDR) factory setting is 48. You may have changed the setting during module installation. Valid address values are from 0 to 255 (selected value must be a multiple of 8). To change the setting, refer to Figure 2-2.

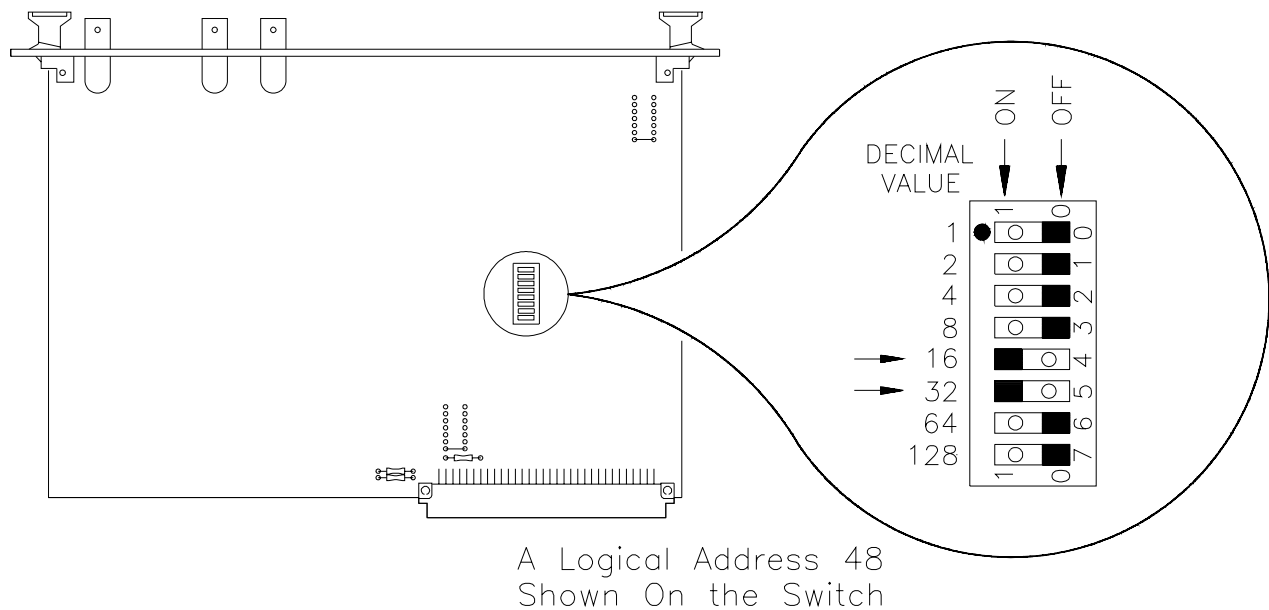

Figure 2-2. Address Selection

VXIbus Interrupt Lines

The Counter sends interrupts to, and receives acknowledgments from, the slot 0 module via the VXIbus backplane interrupt lines. Figure 2-3 shows the locations of the jumpers used to select an interrupt line. For most applications where the counter is installed in an HP 75000 Series B or Series C mainframe, the jumpers do not have to be moved.

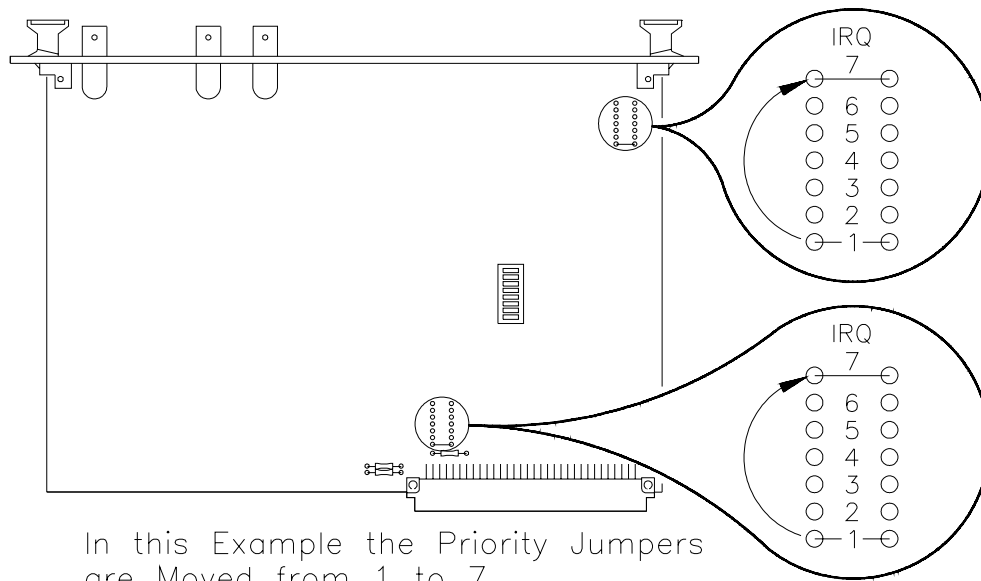

Figure 2-3. Changing the Priority Interrupt Level Jumpers

Interrupt Priority

In the HP 75000 Series B and Series C mainframes, the VXIbus interrupt lines have the same priority. Interrupt priority is established by installing modules in slots numerically closest to the slot 0 module. Thus, slot 1 (internal on the Series B mainframe) has a higher priority than slot 2 (also internal), slot 2 has a higher priority than slot 3, and so on.

Note

Both jumper locations must have the same interrupt priority level jumper (IRQ) installed.

Chapter 3

Using the HP E1333A Universal Counter

Using This Chapter

This chapter uses examples to show how to use the 3-Channel Universal Counter. The examples give you some familiarity with the Standard Commands for Programmable Instruments (SCPI) and with all of the Counter measurement functions. Refer to Chapter 4 “Understanding the Universal Counter” for more information. This chapter contains the following sections:

- Default Conditions Page 20
- Input Signal Constraints. Page 21
- Measurement Procedure. Page 21
- Totalizing Events Page 25
- Frequency Measurement Page 27
- Ratio Measurement Page 29
- Period Average Measurement Page 31
- Pulse Width Measurement Page 32
- Time Interval Measurement. Page 34

Table 3-1. Counter Commands Used in Chapter 3

Command	Description
*RST	Sets the hardware and software to a known state.
CONF[1 2 3]:xxxx	Configures the Counter to the selected measurement function but does not initiate the measurement.
INIT[1 2 3]	Initiates the selected measurement and transfers the reading to mainframe/command module memory. Used with CONF.
FETC[1 2 3]?	Transfers the most recent measurement from the mainframe/command module memory to the output buffer. Used with INIT.
MEAS[1 2 3]:xxxx?	Configures the Counter to the selected measurement function, initiates the measurement, and transfers the reading to the output buffer.
SENS[1 2]:xxxx	Used to change selected measurement default parameters, such as event level, slope, etc.
INP:xxxx	Used to change the input characteristic default parameters on channels 1 and 2 (e.g., coupling, etc.)
[1 2 3] = channel numbers, xxxx = measurement function or parameter	

Default Conditions

When the Counter is turned on or reset (*RST command), the input and measurement parameters are set to their default values. Unless these parameters are changed prior to performing the measurement, the default values will be used.

Table 3-2 lists the parameters and default values for the measurement functions described in Chapter 3. A reference is provided to the measurement name and its associated example program line number where the default is changed. Chapter 4 “Understanding the Universal Counter” contains the complete list of default parameters.

Table 3-2. Reset (*RST) Default Conditions and Values

Parameter	Default	Example of Changing Default
Input		
Attenuation	0 dB	Frequency (line 20)
Impedance	1 MΩ	Frequency (line 20)
Coupling	AC	Time Interval (line 60)
Low-Pass Filter State (on/off)	Off	Totalizing Events (line 40)
Trigger		
Source	Immediate	
Event		
Level	0 V	Totalizing Events (lines 20 and 30)
Slope	Positive	Time Interval (lines 20 and 30)
Function	FREQ	
Frequency		
Range	Auto	Frequency (line 30)
Resolution	5 digits*	Frequency (line 30)
Period		
Range	Auto	Period (line 30)
Resolution	5 digits*	Period (line 30)
* When DEFault resolution is selected, measurements will be made to 5 digits of resolution (4 digits of resolution for the RATIo function).		

Input Signal Constraints

Table 3-3 lists the input signal constraints used for Counter measurements. Complete specifications for the Counter are listed in Appendix A.

Table 3-3. Input Signal Constraints

Parameter	Channels 1 and 2 Input Level		Channel 3
	Normal	/10	
Minimum frequency	DC	DC	75 MHz
Maximum frequency	100 MHz	100 MHz	1 GHz
Minimum time interval/pulse width	200 nsec	200 nsec	
Maximum time interval/pulse width	6871 sec	6871 sec	
Maximum input	5 V	42 V	5 V
Minimum sensitivity	25 mV	250 mV	10 mV to 40 mV
Event detection			
Maximum Level	2.5 V	25 V	0 V
Level Step size	20 mV	200 mV	

CAUTION

MAXIMUM VOLTAGE. The maximum voltage that may be applied to any input connector is 42V for the 1 MΩ input impedance (channels 1 and 2) and 5 Vrms for the 50Ω input impedance (channels 1, 2, and 3). In general, the limiting factor is the maximum power which cannot exceed 0.5W.

Measurement Procedure

The examples in this chapter help you familiarize yourself with the functions of the Counter and some of the SCPI commands used by the Counter. After familiarization, your actual counter measurements are most successful if the following measurement procedure is followed:

1. Have some understanding of the type of signal you want to measure; its amplitude, frequency; is it periodic and repetitive? An understanding of the signal you want to measure will help you select the correct input signal conditioning and measurement commands.
2. Set the input signal conditioning of the measurement channel (event level, event slope, input attenuation, coupling, impedance, and enable the low-pass filter if required).
3. Select the commands to perform the measurement and execute the commands.

Setting Input Signal Conditioning

Channels 1 and 2 allow you to select event level, event slope, input attenuation, input coupling, and input impedance. Additionally, channels 1 and 2 allow you to enable a low-pass filter.

Note

Attenuation, coupling, impedance, and low-pass filter settings affect channel 1 or 2 simultaneously. Both channels will have identical input signal conditioning settings at any given time. For example, changing the input impedance on channel 1 to 50Ω also changes channel 2 input impedance to 50Ω. Event level and event slope can be set independently since these two parameters define event detection for the measurement.

Event Level

Event level is programmable on channels 1 and 2 but is fixed at 0V on channel 3. Event level is the amplitude of the input signal that triggers a measurement. At turn-on or reset, this level is 0V on all three channels. With this default setting the input signal must transition through 0V to trigger a measurement. Note that if the signal is TTL compatible (for example, typically +0.2V to +3.5V; worst case +0.4V to +2.4V) the event level must be set higher than 0V (typically +1.2V) to be within the TTL signal range and above the noise margin. Figure 3-1 illustrates the relationship of the minimum value of the input signal and the event level setting. The event level is set with the following command:

```
[SENSn:]EVEN:LEV xxx (n = channel number, xxx = event level voltage)
```

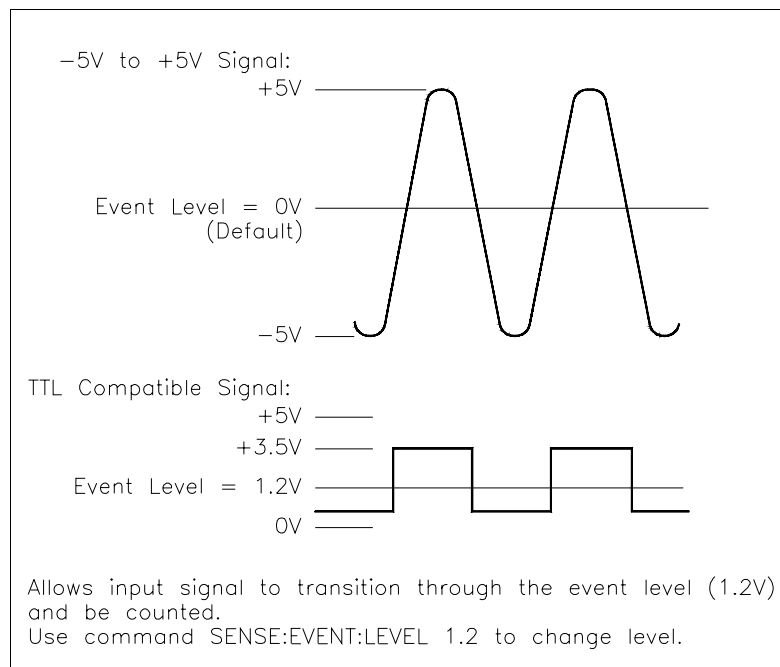

Figure 3-1. Event Level Setting

Event Slope

Event slope specifies either the positive or negative slope of the input signal for triggering the measurement. At turn-on or reset, the event slope is set positive. Changing event slope only affects the time interval function where it is used to specify the rising or falling edge that begins and completes the measurement. Event slope is set with the following command:

```
[SENS $n$ :]EVEN:SLOP  $xxx$  ( $n$  = channel number,  $xxx$  = POS or NEG)
```

Input Attenuation

Maximum input levels for a channel must not be exceeded. A 20 dB attenuator is available on channels 1 and 2 allowing you to divide the input by 10. See maximum input levels in Table 3-3 for the 50 Ω and 1 M Ω input impedance selections. In general, the maximum input power must not exceed 0.5W. You can also use the input attenuator to reduce the sensitivity of the Counter's front end. Input attenuation is set with the following command:

```
INP:ATT  $xxx$  ( $xxx$  = number | MIN | MAX | DEF)
```

Input Coupling

Channels 1 and 2 allow you to select AC or DC coupling. Input coupling is set with the following command:

```
INP:COUP  $xx$  ( $xx$  = AC | DC)
```

AC Coupling

Figure 3-2 illustrates two examples where AC coupling is required for input coupling. The first example is a high frequency signal that is to be measured riding on a very low frequency signal. On high excursions of the low frequency signal, the signal of interest is out of range of the maximum event level setting and cannot trigger the counter. An erroneous count will result. AC coupling the input removes the low frequency component and allows the event level to trigger the signal of interest for an accurate count.

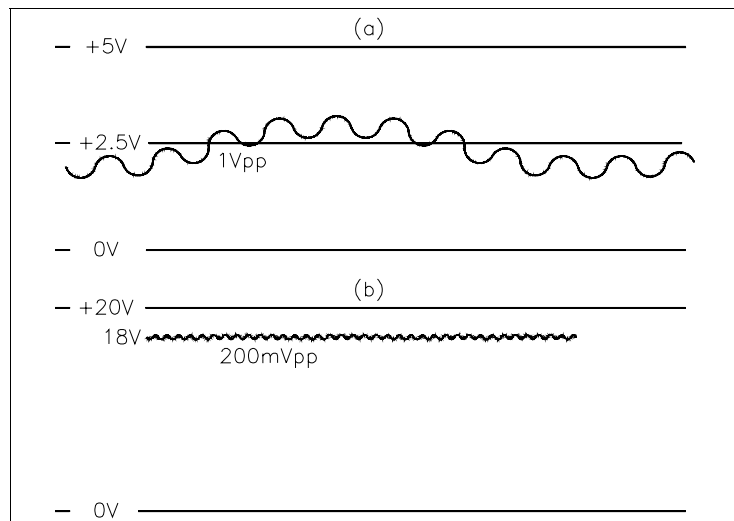

Figure 3-2. Using AC Coupling

The second example is a 200 mV signal of interest with an 18 Vdc component. If the signal is attenuated by 10 to be in the range of the event level, the signal of interest is attenuated to 20 mV and is below the counter's sensitivity. AC coupling the input removes the DC component and allows you to measure the 200 mV signal with a 0V event level.

DC Coupling DC coupling "fixes" the DC level of the input signal. With a DC coupled input, you can set the event level for triggering a measurement at an exact point on the waveform. The pulse width and time interval examples, later in this chapter, illustrates the use of DC coupling. To use DC coupling and fix the event level point, do the following:

- View the input signal on an oscilloscope using DC coupling and note the DC level of the point you want to measure.
- Connect the signal to the counter. Set the Counter to DC coupling and set the event level for the DC level of the point you noted in the previous step.

Note DC coupling should be used to count (TOTAlize) square waves. DC coupling prevents a square wave input signal from being differentiated by the presence of a coupling capacitor which causes additional counts.

Input Impedance You can select either 1 M Ω or 50 Ω input impedance on channels 1 and 2. 1 M Ω is the turn-on and reset value. Channel 3 has a fixed 50 Ω input impedance. Input impedance is set with the following command:

```
INP:IMP xxx (xxx = number | MIN | MAX | DEF)
```

Input Low-Pass Filter A low-pass filter can be enabled on channels 1 and 2. Each filter has a 100 kHz 3 dB point. The filter is effective in reducing the effects of normal mode noise on measurements. You enable the input filter with the following command:

```
INP:FILT xxx (xxx = OFF | 0 | ON | 1)
```

Note The low-pass filter should be enabled when measuring signals <100 kHz to remove glitches and noise that could cause erroneous counts. Use of the filter is especially important when making PERiod measurements.

Measurement Examples The remainder of this chapter gives an example of each measurement function the Counter can perform. Input signal conditioning for each example is itemized as discussed previously. All example programs use an HP Series 200/300 computer with HP BASIC. The address for the Counter uses an HP-IB select code of 7, mainframe address of 09, and secondary address of 06 (Counter logical address 48 as shipped from the factory).

Totalizing Events

The following is a summary of the TOTalize function.

- Will totalize events on channel 1 or 2. Maximum reading is 68.7 billion counts (36 bits).
- Will simultaneously totalize events on channels 1 and 2.
- Reading the accumulated count will not stop the totalize function or reset the counter. This allows for cumulative counting.
- The totalize function continues counting events until the function for the channel is changed.
- Overflow (>36 bits) information is only updated when the counter is read with the FETCh? command. See the STATus subsystem section in Chapter 5 for information on overflow indication.

Example: Counting Events

In this example, the Counter counts the number of Form-C Switch transitions. This example also shows the Counter's ability to count events in parallel on channels 1 and 2.

Figure 3-3 shows how to connect the Form-C Switch through an RS flip-flop (debounced count) to channel 1. The direct connection from the Form-C Switch to channel 2 is the "raw count". Channel 1 will count 1 for each contact closure. Channel 2 will count a large number for each contact closure (switch transition plus the contact bounce).

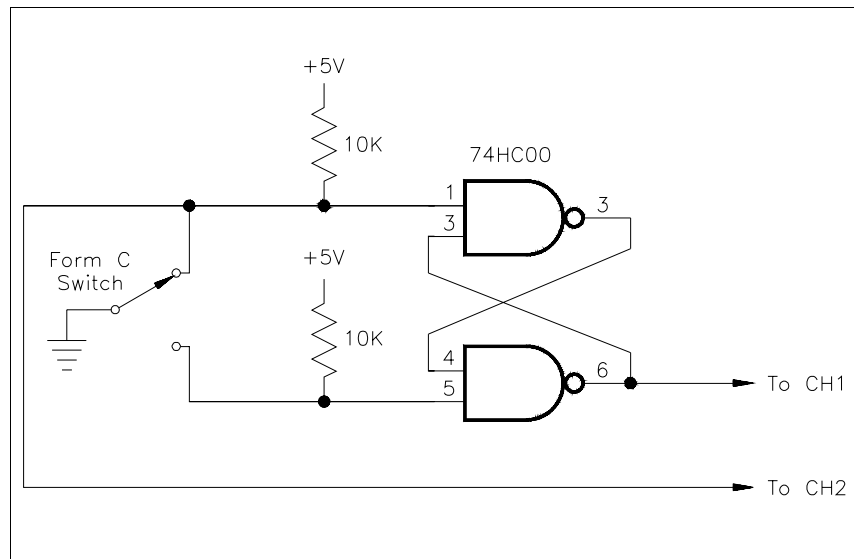

Figure 3-3. Counting Events (Totalize)

Input Signal Conditioning

- **Event Level:** Input levels are TTL. Event level is set to +1.2V so the input signal will transition through the event level and trigger a count.
- **Event Slope:** Changing event slope has no effect on totalize measurements.
- **Attenuation:** No attenuation needed; the default of 0 dB is used.
- **Coupling:** DC coupling is used to prevent differentiation error.
- **Filter:** The low-pass filter is enabled to help remove high frequency signals picked up on the cabling.
- **Impedance:** The default 1 M Ω input impedance is used.

Execute:

```
10 OUTPUT 70906;"*RST"           !Resets the Counter to its default
                                state
20 OUTPUT 70906;"EVEN:LEV 1.2"    !Sets event level for channel 1 to
                                +1.2V
30 OUTPUT 70906;"SENS2:EVEN:LEV 1.2"
                                !Sets event level for channel 2 to
                                +1.2V
40 OUTPUT 70906;"INP:FILT ON;COUP DC"
                                !Enables the LP filter and DC
                                coupling for channels 1 and 2
50 OUTPUT 70906;"CONF1:TOT;:CONF2:TOT"
                                !Configures channel 1 and 2 for
                                totalize measurement
60 OUTPUT 70906;INIT1;:INIT2"    !Starts channels 1 and 2 counting
70 FETC1?                        !Transfers channel 1 count to the
                                output buffer; counting continues
                                after transfer
80 ENTER 70906;A                 !Transfers the measurement from
                                the output buffer to the input buffer
                                of the computer
90 FETC2?                        !Transfers channel 2 count to the
                                output buffer; counting continues
                                after transfer
100 ENTER 70906;B                !Transfers the measurement from
                                the output buffer to the input buffer
                                of the computer
110 PRINT TABXY(1,10),"DEBOUNCED COUNT = ",A," "
                                !Displays count on computer
120 PRINT TABXY(1,12),"RAW COUNT = ",B," "
130 GOTO 70                       !Causes an infinite loop that
                                displays the switch activity
140 END                           !Terminates program
```

Comments

Related SCPI Commands. Commands associated with the totalize function but not discussed in this example are: ABORt, INPut, SENSE, TRIGger.

Frequency Measurement

The following is a summary of the FREQUENCY function.

- Frequency can be measured on channels 1, 2, or 3. When measuring frequency on one of the three channels, the other two channels cannot be used (no simultaneous measurements). Signal connections to the other channels can be present.
- Measurement range is DC to 100 MHz for channels 1 and 2; 75 MHz to 1 GHz on channel 3.
- See the STATus subsystem section in Chapter 5 for information on overflow indication.

Example: Making a Frequency Measurement

This example uses the Counter to measure three different frequencies which simulate an audio receiver and illustrate the measurement capability of all three channels. Figure 3-4 shows a block diagram of the receiver simulation. Use three frequency sources for this simulation. The channel 1 input is a 2100 Hz sine wave simulating the output of the detector. The channel 2 input is a 10 MHz sine wave simulating the IF of the receiver. The signals to channels 1 and 2 are expected to have an amplitude of $\pm 10V$. The channel 3 input is a 500 MHz, +5V sine wave simulating the local oscillator of the receiver. Shielded cables should be used to prevent high frequency noise from entering the counter through the cables since the low-pass filter is disabled.

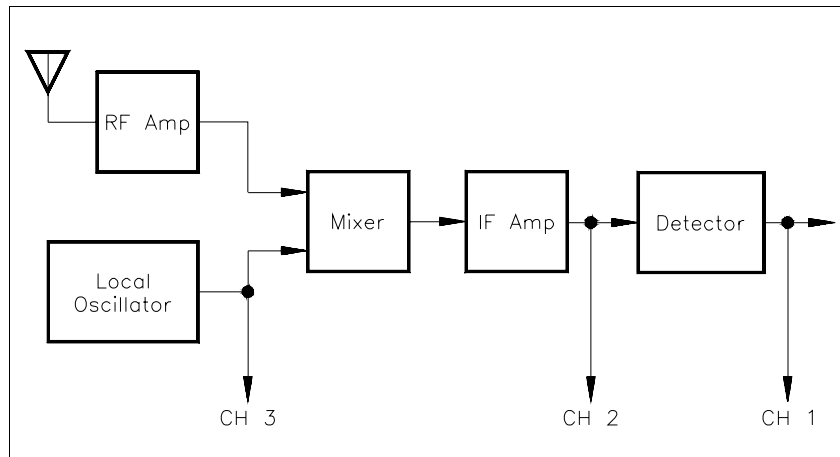

Figure 3-4. Frequency Measurement

Input Signal Conditioning

- **Event Level:** The default event level of 0V can be used since all input signals are symmetrical about 0V.
- **Event Slope:** Changing event slope has no effect on frequency measurements.
- **Attenuation:** 20 dB of attenuation is programmed.
- **Coupling:** AC coupling is used (default).
- **Filter:** The low-pass filter is disabled (default setting).
- **Impedance:** Input impedance is set to 50 Ω .

Execute:

```
10 OUTPUT 70906;"*RST"           !Resets counter to its default state
20 OUTPUT 70906;"INP:ATT 20;IMP 50"!Sets channels 1 and 2 input
                                !attenuation to 20 dB and input
                                !impedance to 50Ω
30 OUTPUT 70906;"MEAS1:FREQ?"    !Configures channel 1 for
                                !frequency measurement, performs
                                !the actual measurement, then
                                !transfers the measurement results
                                !to the output buffer.
40 ENTER 70906;C                 !Transfers the channel 1
                                !measurement from the output
                                !buffer to the input buffer of the
                                !computer
50 PRINT C                       !Displays measurement on
                                !computer
60 OUTPUT 70906;"MEAS2:FREQ?"    !Configures channel 2 for
                                !frequency measurement, performs
                                !the actual measurement, then
                                !transfers the measurement results
                                !to the output buffer
70 ENTER 70906;D                 !Transfers the channel 2
                                !measurement from the output
                                !buffer to the input buffer of the
                                !computer
80 PRINT D                       !Displays measurement on
                                !computer
90 OUTPUT 70906;"MEAS3:FREQ?"    !Configures channel 3 for
                                !frequency measurement, performs
                                !the actual measurement, then
                                !transfers the measurement results
                                !to the output buffer
100 ENTER 70906;E                !Transfers the channel 2
                                !measurement from the output
                                !buffer to the input buffer of the
                                !computer
110 PRINT E                      !Displays measurement on
                                !computer
120 END                          !Terminates program and
                                !measurement
```

Comments **Measurement Time.** Time needed to complete the measurement is dependent on both the signal input frequency and the resolution specified, and could take a maximum of 6871 seconds to complete. See Chapter 4, “Understanding the Universal Counter” for additional information.

Related SCPI Commands. Commands that are associated with frequency measurements but do not discussed in this example are: CONFigure, INItiate, SENSE, TRIGger,.

Ratio Measurement

The following summarizes the ratio function:

- Ratio is measured on channels 1 and 2. The channel specified in the command is the numerator of the ratio e.g., MEAS1:RAT results in the ratio of frequencies of channel 1 to channel 2 (CH1/CH2); MEAS2:RAT results in the ratio of frequencies of channel 2 to channel 1 (CH2/CH1).
- Minimum ratio value is 9.3E-10; maximum ratio value is 1E9.
- The number of periods the ratio is counted over can be selected.

Example: Making a Ratio Measurement

This example uses the Counter to measure the ratio of two different frequencies. Figure 3-5 shows two circuits that generate a frequency different from the original frequency; one is a divide by 2, 4, 8, and 16 counter while the other is a X2 frequency multiplier. The original frequency is input to the circuit and to channel 1. The output of the circuit is input to channel 2. The example program measures the ratio of the input to the output of the example circuits.

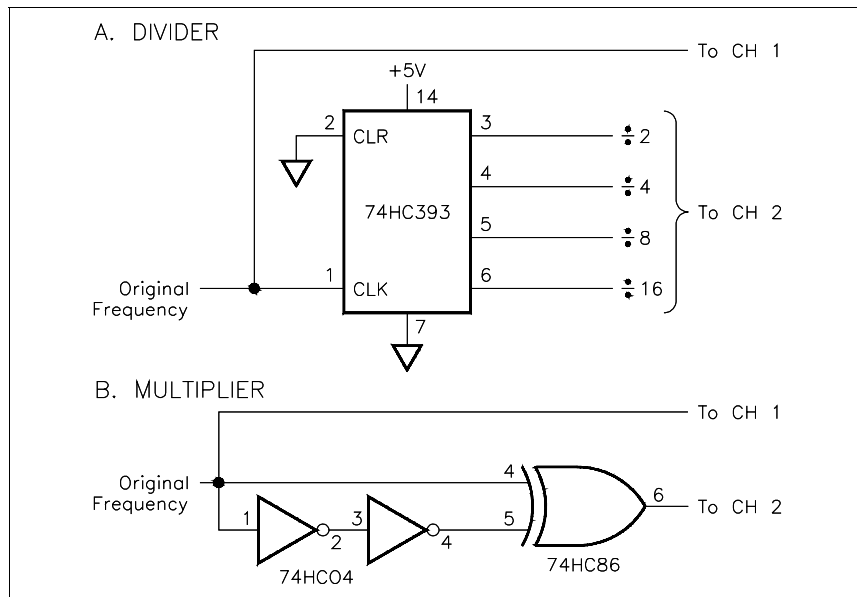

Figure 3-5. Ratio Measurement Example

Input Signal Conditioning

- **Event Level:** Since the two signals are TTL (typically +0.2 to +3.5V), a 0V event level results in counting noise. The event level must be set greater than 0V. This example sets it to +1.2V.
- **Event Slope:** Event slope does not affect ratio measurements.
- **Attenuation:** The default attenuation of 0 dB is used.
- **Coupling:** DC coupling is used because of a TTL level.
- **Filter:** The default state of the filter (disabled) is used.
- **Impedance:** Input impedance is set to 1 M Ω .

Execute:

```
10  OUTPUT 70906;"*RST"           !Resets the Counter to its default  
                                     state  
20  OUTPUT 70906;"INP:COUP DC"    !Sets channels 1 and 2 input  
                                     coupling to DC  
30  OUTPUT 70906;"EVEN:LEV 1.2"   !Set channel 1 event level to +1.2V  
40  OUTPUT 70906;"SENS2:EVEN:LEV 1.2" !Set channel 2 event level to +1.2V  
50  OUTPUT 70906;"MEAS1:RAT?"     !Configures channel 1 and 2 for  
                                     ratio measurement with CH 1 as  
                                     numerator, performs the actual  
                                     measurement, then transfers the  
                                     measurement results to the output  
                                     buffer  
60  ENTER 70906;F                 !Transfers the ratio measurement  
                                     from the output buffer to the input  
                                     buffer of the computer  
70  PRINT F                       !Displays measurement on  
                                     computer  
80  END                           !Terminates program and  
                                     measurement
```

You can obtain the inverse ratio of the measurement obtained in the above example by changing the MEAS command in line 50 to MEAS2:RAT?.

Comments **Cabling.** Shielded cables must be used since the filter is disabled. Enable the filter if you are operating in a high noise environment.

Measurement Time. Time needed to complete the measurement is dependent on both the signal input frequency and the resolution specified. If a resolution requires that the maximum number of periods be counted ($6.8719\text{E}+10$) and the input signals are low frequency, the measurement could take an extremely long time to complete. See Chapter 4, “Understanding the Universal Counter” for additional information.

Related SCPI Commands. Commands associated with ratio measurements but not discussed in this example are: ABORt, CONFigure, SENSE, TRIGger.

Period Average Measurement

- Period average can be measured on channel 1 or 2.
- Channel 2 cannot be used when channel 1 is measuring period average and vice versa. You can have input signals connected to all inputs.
- Measurement range is 10 nsec to 6871 sec.
- See the STATus subsystem section in Chapter 5 for information on overflow indication.

Example: Making a Period Average Measurement

Input Signal Conditioning

This example uses the Counter to measure the average period of a test signal. The input to channel 1 is expected to be a 10 MHz TTL compatible clock pulse.

- **Event Level:** Event level is set to +1.2V for a typical TTL signal (+0.2 to +3.5V).
- **Event Slope:** Not used on the period function.
- **Attenuation:** The default of 0 dB is used.
- **Coupling:** DC coupling is used because of a TTL signal.
- **Filter:** The input low-pass filter is disabled.
- **Impedance:** Input impedance is 1 M Ω .

Execute:

```
10 OUTPUT 70906;"*RST"           !Resets the counter
20 OUTPUT 70906;"INP:COUP DC"     !Sets channels 1 and 2 input to DC
30 OUTPUT 70906;"EVEN:LEV 1.2"    !Sets the event level to +1.2V
40 OUTPUT 70906;"MEAS1:PER? 1E-7,1E-15"
                                   !Configures channel 1 for period
                                   measurement, sets period to .1 $\mu$ sec
                                   at 1E-15 sec. resolution, performs
                                   the measurement, transfers results
                                   to output buffer

50 ENTER 70906;G                 !Transfers channel 1 measurement
                                   from output buffer to the input
                                   buffer of the computer

60 PRINT G                       !Displays measurement
70 END                           !Terminates program
```

Comments

Measurement Time. Time needed to complete the measurement is dependent on both the signal input frequency and the resolution specified, and could take a maximum of 6871 seconds to complete. See Chapter 4, "Understanding the Universal Counter" for additional information.

Related SCPI Commands. Commands associated with period measurements but not discussed in this example are: ABORt, CONFigure, SENSE, TRIGger.

Pulse Width Measurement

- Pulse width can be measured on channel 1 or 2.
- Channel 1 cannot be used when channel 2 is measuring pulse width and vice versa.
- Positive and negative pulse widths can be measured. Positive pulse width is measured from rising to falling edge, and negative pulse width is measured from falling to rising edge.
- Measurement range is 200 nsec to 6871 seconds.
- Resolution is selectable from 100 nsec to 1 nsec.
- See the STATus subsystem section in Chapter 5 for information on overflow indication.

Example: Making a Pulse Width Measurement

This example uses channel 2 of the Counter to measure the pulse width of the sync pulses in the horizontal portion of a composite video waveform. The horizontal portion of a composite video waveform consists of horizontal lines, each containing video information. It also contains sync pulses which provide blanking, retrace time, and other information. Figure 3-6 shows a composite video waveform.

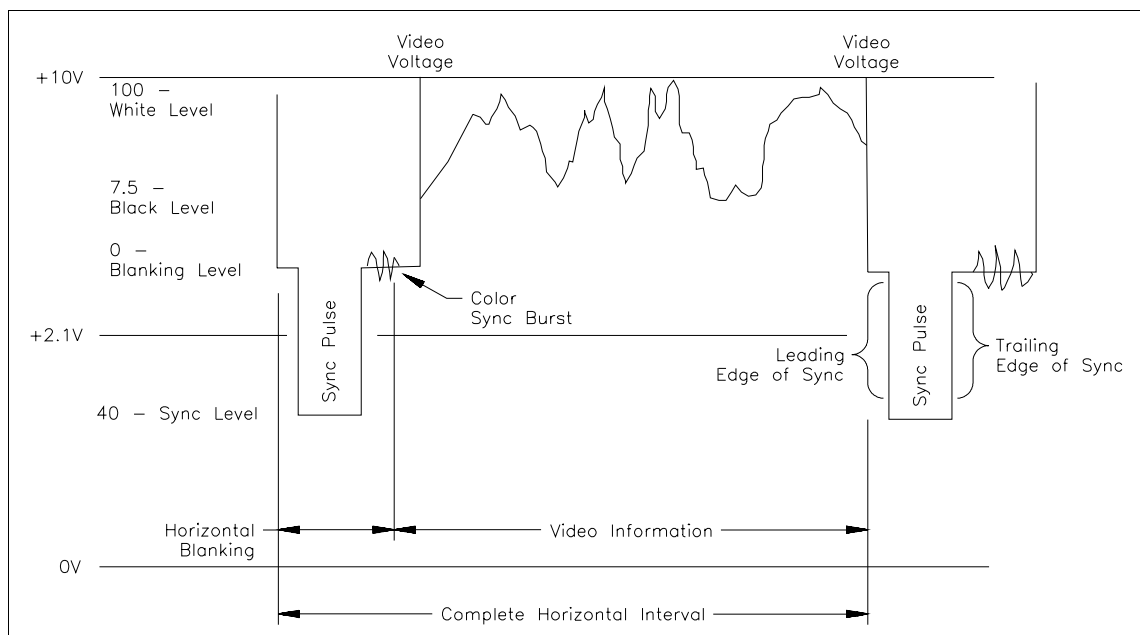

Figure 3-6. Composite Horizontal Video Signal

To accurately measure the pulse width of the sync pulse, the event level must be set so only sync pulse transitions trigger a measurement. See “Setting Input Signal Conditioning” on page 22 for information on setting the event level.

Input Signal Conditioning

- **Event Level:** Event level is set to +2.1V.
- **Event Slope:** Not used on the pulse width function.
- **Attenuation:** The default of 0 dB is used.
- **Coupling:** DC coupling is set (see “Setting Input Signal Conditioning” on page 22).
- **Filter:** The low-pass filter is disabled.
- **Impedance:** Input impedance is programmed to 50Ω (see program line 20).

Execute:

```
10 OUTPUT 70906;"*RST"           !Resets the counter to its default
                                   state.
20 OUTPUT 70906;"INP:COUP DC;IMP MIN"
                                   !Sets input impedance to 50 ohms
                                   and set coupling to DC
30 OUTPUT 70906;"SENS2:EVEN:LEV 2.1"
                                   !Sets event level to +2.1V
40 OUTPUT 70906;"MEAS2:NWID?"    !Configures channel 2 for negative
                                   pulse width measurement,
                                   performs the actual measurement,
                                   then transfers the measurement
                                   results to the output buffer
50 ENTER 70906; H                !Transfers the channel 2
                                   measurement from the output
                                   buffer to the input buffer of the
                                   computer
60 PRINT H                       !Displays measurement on
                                   computer
70 END                            !Terminates program and
                                   measurement
```

Note

The MEASure command in the above example does not specify a resolution. Therefore, the 100 nsec default resolution is used which requires only one measurement. If a resolution less than 100 nsec is specified in line 40 such as 10 nsec (for example, “MEAS2:NWID? 1E-7,1E-8”), the Counter will make 16 measurements and calculate an average.

Comments

Measurement Time. Positive and negative pulse width measurements will continue until the second edge is detected. If the second edge is not detected within 6871 seconds, an overflow occurs.

Related SCPI Commands. Commands associated with pulse width measurements but not discussed in this example are: ABORt, CONFigure, SENSE, TRIGger.

Time Interval Measurement

- Time interval of any event can be measured from channel 1 to 2 or 2 to 1.
- Can be selected to start and/or stop on rising or falling edge.
- Measurement range is 200 nsec to 6871 seconds.
- Resolution is selectable from 100 nsec to 1 nsec.
- See the STATus subsystem section in Chapter 5 for information on overflow indication.

Example: Making a Time Interval Measurement

This example uses the Counter to measure the time interval between the leading edges of the sync pulses in Figure 3-6. This measurement requires the signal be input into both channels 1 and 2.

Input Signal Conditioning

- **Event Level:** Event level is set to +2.1V.
- **Event Slope:** Event slope is set to NEGative.
- **Attenuation:** The default of 0 dB is used.
- **Coupling:** DC coupling is used.
- **Filter:** The default setting of filter disabled is used.
- **Impedance:** Input impedance is set to 50 Ω (see program line 60).

Execute:

```
10 OUTPUT 70906;"*RST"           !Resets the counter to its default state
20 OUTPUT 70906;"SENS1:EVEN:SLOP NEG"
                                   !Selects channel 1 event slope to
                                   negative edge
30 OUTPUT 70906;"SENS2:EVEN:SLOP NEG"
                                   !Selects channel 2 event slope to
                                   negative edge
40 OUTPUT 70906;"SENS1:EVEN:LEV 2.1"
                                   !Sets channel 1 event level to +2.1V
50 OUTPUT 70906;"SENS2:EVEN:LEV 2.1"
                                   !Sets channel 2 event level to +2.1V
60 OUTPUT 70906;"INP:COUP DC;IMP 50"
                                   !Sets coupling to DC and input
                                   impedance for channels 1 and 2 to
                                   50 ohms
70 OUTPUT 70906;"MEAS1:TINT?"     !Configures channel 1 and 2 for
                                   time interval measurement
                                   (channel 1 as the start event),
                                   performs the actual measurement,
                                   then transfers the measurement
                                   results to the output buffer
80 ENTER 70906;J                 !Transfers the measurement from
                                   the output buffer to the input buffer
                                   of the computer
90 PRINT J                       !Displays measurement on computer
100 END                          !Terminates program
```

Note The MEASure command in the above example does not specify a resolution. Therefore, the 100 nsec default resolution is used which requires only one measurement. If a resolution less than 100 nsec is specified in line 70 such as 10 nsec (for example, “MEAS1:TINT? 1E-3,1E-8”), the Counter will make 16 measurements and calculate an average.

Comments **Measurement Time.** Time interval measurement will continue until the second edge is detected. If the second edge is not detected within 6871 seconds, an overflow occurs.

Related SCPI Commands. Commands associated with time interval measurements but not discussed in this example are: ABORt, CONFigure, SENSE, TRIGger.

Chapter 4

Understanding the HP E1333A Universal Counter

Using This Chapter

This chapter shows how to configure the E1333A 3-Channel Universal Counter when performing measurements. It describes the commands and helps you determine settings to optimize performance. This chapter contains the following sections:

- Counter Configuration Page 37
- Measurement Procedure. Page 39
- Selecting Input Parameters Page 40
- Measurement Functions Page 42
- Selecting Range and Resolution Page 46
- Selecting Aperture Time and Number of Periods Page 47
- Selecting Trigger Source Page 50
- Synchronizing Instruments Page 52
- Synchronizing the Counter with a Computer Page 52
- Checking for Errors Page 53
- Checking for Overflow Page 54
- Querying the Counter. Page 56

Counter Configuration

The Counter performs measurement functions using various SCPI commands to specify measurement requirements or counter configurations. When the Counter is first turned on or reset (*RST command), the input and measurement parameters are set to their default values. Unless these parameters are changed prior to performing the measurement, the default values will be used. Table 4-1 lists (in alphabetical order) the various commands, along with the default values at turn-on or reset, and where in Chapter 4 you can find specific programming information.

Note Some commands in Table 4-1 appear in square brackets ([]). These commands are called *implied* commands and are fully explained in Chapter 5. It is important to note that if the implied command is used, the square brackets ([]) are not part of the command and are not sent to the instrument.

Table 4-1. Counter SCPI Commands and *RST (Reset) Default Information

Command	Description	Default	Where to find in Chapter 4
ABORt	Abort Measurement		Measurement Functions
CONF _n : TOT FREQ RAT PER PWID NWID TINT	Configure Measurements for: Totalize Frequency Ratio Period Average Positive Pulse Width Negative Pulse Width Time Interval	FREQ	Measurement Functions Measurement Functions Measurement Functions Measurement Functions Measurement Functions Measurement Functions Measurement Functions
FETC _n ?	Fetch Measurement Results		Measurement Functions
INIT _n	Initiate Configured Measurement		Measurement Functions
INP: ATT COUP FILT[:LPAS][:STATe] IMP	Input Configuration Attenuation Coupling Filter State Impedance	0dB AC OFF 1MΩ	Selecting Input Parameters Selecting Input Parameters Selecting Input Parameters Selecting Input Parameters Selecting Input Parameters
MEAS _n : FREQ? [<range>[, <resolution>]] PER? [<range>[, <resolution>]] RAT? PWID? NWID TINT?	Perform Measurement for: Frequency: Range Resolution Period: Range Resolution Ratio Positive Pulse Width Negative Pulse Width Time Interval	FREQ AUTO 5 digits AUTO 5 digits	Measurement Functions Measurement Functions Selecting Range and Resolution Selecting Range and Resolution Measurement Functions Selecting Range and Resolution Selecting Range and Resolution Measurement Functions Measurement Functions Measurement Functions
READ?	Perform configured measurement		Measurement Functions
SENS _n : EVEN:LEV EVEN:SLOP FREQ:APER FUNC: FREQ NWID PER PWID RAT TINT TOT PER:NPER	Event Level Event Slope Frequency Aperture Time Measurement Function For Frequency Negative Pulse Width Period Positive Pulse Width Ratio Time Interval Totalize Period Average Number	0 V Positive 2 msec* FREQ 2 cycles*	Selecting Input Parameters Selecting Input Parameters Selecting Aperture Time Measurement Functions Measurement Functions Measurement Functions Measurement Functions Measurement Functions Measurement Functions Measurement Functions Measurement Functions Measurement Functions
STAT:QUES :COND? :ENAB :ENAB? [:EVEN?]	Status Questionable Condition Register query Set Enable register Enable register query Event register query	0 0 0 0	
SYST:ERR?	System Error query		Checking for Errors
TRIG [:IMM] :SOUR	Trigger State Trigger Source	Immediate	Selecting Trigger Source Selecting Trigger Source
* FREQ:APER and PER:NPER values are ignored in AUTO range. <i>n</i> = channel number.			

Measurement Procedure

Counter measurements are most successful if the following measurement procedure is followed.

1. Have some understanding of the type of signal you want to measure; its amplitude and frequency; is it periodic and repetitive? An understanding of the signal you want to measure will help you select the correct signal conditioning and measurement commands.
2. Set the input parameters (attenuation, coupling, impedance, filter, event level, etc). See “Selecting Input Parameters” on page 40 for more information.
3. Perform the measurement. The same measurement can be made using various commands. See “Measurement Functions” on page 42 for more information. If necessary, modify the measurement selection to meet desired input requirements or optimize measurements.
 - Frequency or period measurement range and resolution. See “Selecting Range and Resolution” on page 46.
 - Frequency measurement aperture time. See “Selecting Aperture Time and Number of Periods” on page 47.
 - Ratio measurement number of periods. See “Selecting Aperture Time and Number of Periods” on page 47.
 - Period measurement number of periods. See “Selecting Aperture Time and Number of Periods” on page 47.
 - Trigger source. See “Selecting Trigger Source” on page 50.

Selecting Input Parameters

Before a measurement can be performed, it is necessary to set up the Counter input and triggering circuits for the desired input signal. If these values are not changed prior to performing the measurement, the default values listed in Table 4-1 will be used. Instructions for selection of the Input Signal Conditioning and Event Slope and Level are provided below.

Input Signal Conditioning

This section discusses the input signal conditioning controls you can program with the INPut command. These controls allow the selection of:

- Input Attenuation
- Input Coupling
- Input Filter State
- Input Impedance

Note

The INPut signal conditioning commands affect both channel 1 and 2 simultaneously and have no effect on channel 3.

Input Attenuation

The input signal can be attenuated by 20 dB (/10) on channels 1 and 2. A direct input (0 dB) is selected at turn-on or reset. You select input attenuation with the following command:

```
INP:ATT <value | MIN | MAX | DEF>
```

Input Coupling

You can select AC or DC coupling for channels 1 and 2. AC coupling is selected at turn-on or reset. You select input coupling with the following command:

```
INP:COUP <AC | DC>
```

Input Low-Pass Filter

Channels 1 and 2 have a programmable low-pass filter with a cut-off frequency of 100 kHz. The filter is disabled at turn-on or reset. You enable the input filter with the following command:

```
INP:FILT[:LPAS][:STAT] <ON | OFF>
```

Input Impedance

Channels 1 and 2 have programmable input impedance of either 50Ω or 1 MΩ. At turn-on or reset, 1 MΩ is selected. You select input impedance with the following command specifying MIN for 50Ω, MAX for 1 MΩ, or DEF for 50Ω.

```
INP:IMP <value | MIN | MAX | DEF>
```

Event Slope and Event Level

This section discusses the input controls you can program with the SENSE command to trigger a count. The Counter has event detection controls on channels 1 and 2. These controls allow the selection of:

- Event Slope
- Event Level

Note Event Slope and Event Level can be programmed for channels 1 and 2 independently. Channel 3 has a fixed event level of 0V with positive event slope.

Event Slope The POSitive (rising) or NEGative (falling) edge of the input signal can be selected as the sense event for channels 1 and 2 independently. POSitive is selected at turn-on or reset. You select Event Slope with the following command specifying either POS or NEG:

SENS*n*:EVEN:SLOP *xxx* (*n* = channel number, *xxx* = POS or NEG)

Event Level Channels 1 and 2 can be programmed to an event level between -2.56 V and +2.54 V in 20 mV steps. Selecting a value outside the range will generate an error. 0 V is selected at turn-on or reset. You select Event Level with the following command:

SENS*n*:EVEN:LEV *xxx* (*n* = channel number, *xxx* = level in volts)

Note When attenuation is set to 20 dB, event levels entered as -2.56 V to +2.54 V in 20 mV steps behave as -25.6 V to +25.4 V in 200 mV steps because the input signal is divided by 10. This is referred to in the text as /10.

Measurement Functions

The Counter can make the following measurements as previously described in Chapter 3, “Using the Universal Counter”.

- Totalize (TOT) [channel 1 or 2]
- Totalize (TOT) [simultaneous event counting on channels 1 and 2]
- Frequency (FREQ) [channel 1, 2, or 3]
- Ratio (RAT) [channel pair 1-2]
- Period (PER) [channel 1 or 2]
- Positive pulse width (PWID) [channel 1 or 2]
- Negative pulse width (NWID) [channel 1 or 2]
- Time interval (TINT) [channel pair 1-2]

Different commands can be used to select and perform the same measurement function. This is possible because SCPI supports three different "levels" of commands. The choice of using different commands to perform the same measurement function offers two advantages:

- It gives the user flexibility in programming the application.
- It allows the use of all the features of the Counter.

For example, the MEASure, CONFigure, and SENSE commands will each set up a FREQUENCY measurement. Two levels are signal oriented (MEAS and CONF); i.e., the command parameters cause the Counter to set up as needed to satisfy the requested measurement. The third level is hardware oriented (SENS); i.e. the command dictates the Counter set up and measurements are made with this fixed set up. The MEASure or CONFigure command will automatically select the aperture time required to obtain 5 digits of resolution, but the SENSE command requires you to select a specific aperture time.

Figure 4-1 illustrates how the data path differs using MEASure, CONFigure, and SENSE:FUNCTION commands with READ?, INITiate, and FETCh? commands. The figure shows how they all perform the same measurement and get the data to the output buffer.

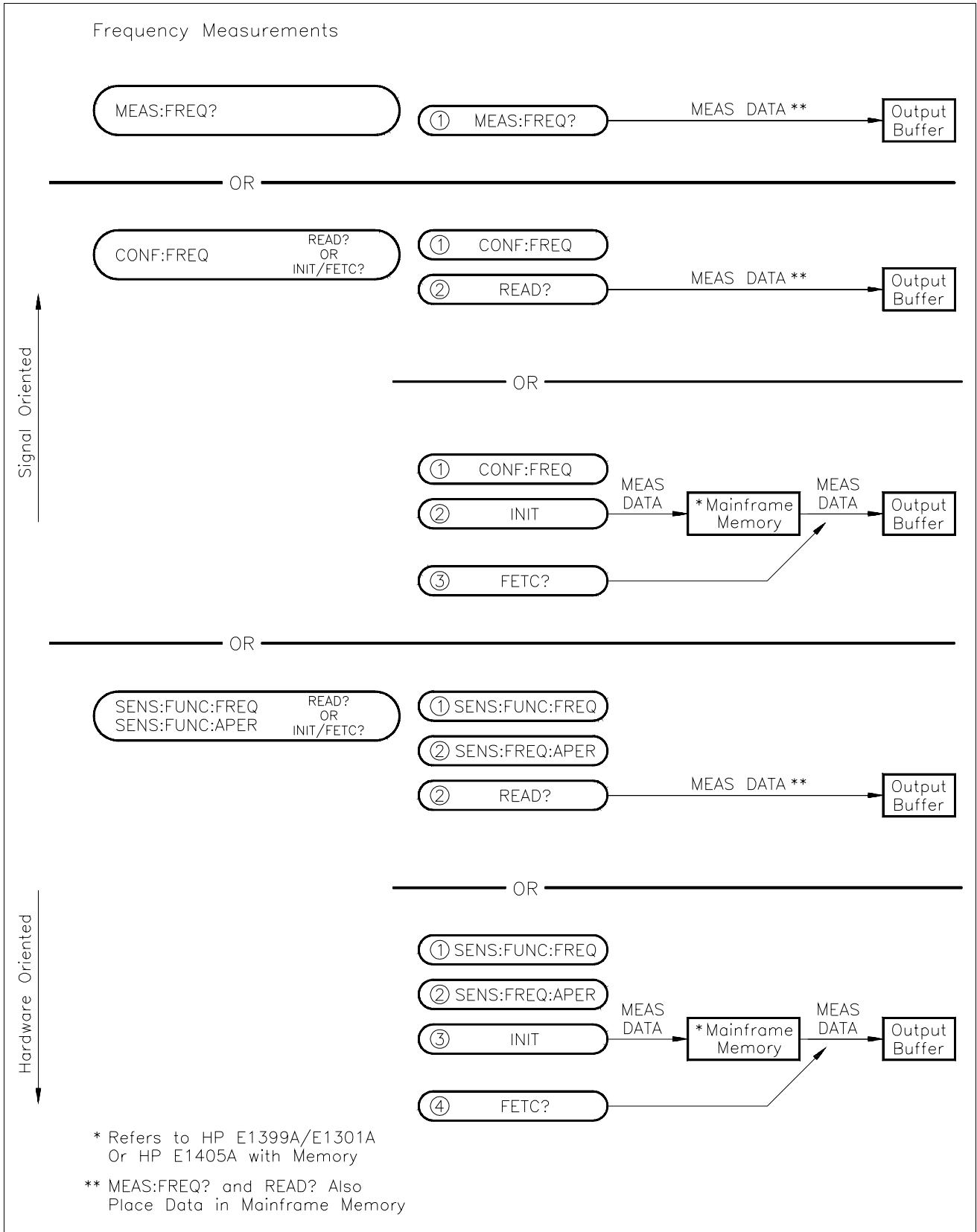

Figure 4-1. Measurement Commands

MEASure, CONFigure, and SENSe:FUNCTion

Only measurements that complete can be performed using the MEASure command. All measurements (including TOTalize) can be configured with the CONFigure or SENSe:FUNCTion, but at least one additional command must then be used to cause a measurement to be made.

The MEASure and CONFigure commands are signal oriented measurement commands. By entering optional measurement parameters, the Counter sets instrument parameters to achieve the specified measurement. The Counter chooses between two measurement techniques (direct frequency or period average measurement) to make the fastest possible measurement. For example, even if the measurement function is frequency, the measurement may be made in the period average mode and inverted by the Counter to return a frequency result if the period average mode is faster.

You make hardware oriented measurements using the SENSe:FUNCTion commands. You fix the type of measurement technique used even if it not the fastest method of measuring. You also fix the aperture time or number of periods used for the measurement.

Using MEASure

MEASure is used to make time related measurements (for example, you cannot totalize with the MEASure command). You select and perform a measurement with the following command:

MEASn:function? (n = channel number, function = FREQ, RAT, PER, PWID, NWID, or TINT)

Note

Range and resolution can be entered for frequency and period measurements using the MEASure command. See “Selecting Range and Resolution” on page 46 for more information.

The measurement data obtained is stored in the mainframe memory and output buffer. Use an enter statement to transfer this data to the computer.

Using CONFigure

CONFigure sets up the configuration, and does not perform the actual measurement. Configure with the following command for a measurement:

CONF n: function (n = channel number, function = TOT, FREQ, RAT, PER, PWID, NWID, or TINT)

Once the selected measurement is configured, the measurement is performed using a READ? or INITiate command.

Note Range and resolution can be entered for frequency and period measurements using the CONFIGure command. See “Selecting Range and Resolution” on page 46 for more information.

Using SENSE:FUNCTION SENSE:FUNCTION only sets up the configuration, and does not perform the actual measurement. Using this command the Counter does not choose the fastest measurement technique. The function you specify will be the measurement technique. Using this command allows the user to specify additional parameters as follows:

- Allows setting of aperture time for frequency measurements. See “Selecting Aperture Time and Number of Periods” on page 47 for information.
- Allows setting the number of periods for period measurements. See “Selecting Aperture Time and Number of Periods” on page 47 for information.

You configure for a measurement with the following command:

SENSn:FUNC?:*function* (*n* = channel number and *function* = TOT, FREQ, RAT, PER, PWID, NWID, or TINT)

The selected measurement is configured, and the measurement is performed using an INITiate or READ? command.

Note The SENSE:FUNCTION command need only be used for frequency, period, and ratio measurements where aperture time or number of periods will be selected. See “Selecting Aperture Time and Number of Periods” on page 47 for more information.

INITiate, READ?, and FETCh?

After the Counter is configured, the INITiate or READ? command is used to perform the actual measurement.

Using INITiate

INITiate performs the configured measurement and transfers the result to the mainframe/command module memory. The INITiate command is the only way to start a totalize measurement. Perform the configured measurement with the following command:

INIT*n* (*n* = channel number)

The selected measurement is performed, and the measurement is stored in mainframe/command module memory. Use the FETCh? command to transfer the result from mainframe/command module memory to the output buffer.

Using READ? READ? performs the configured measurement and transfers the result to the mainframe memory and output buffer. READ? cannot be used on totalize measurements. Perform and read a configured measurement with the following command:

READ*n*? (*n* = channel number)

The measurement result is then available to be transferred into the computer.

Using FETCh? FETCh? retrieves the most recent measurement from the mainframe/command module memory, and transfers it to the output buffer. For TOTalizing events, the measurement is read directly from the Counter. Therefore, FETCh? must be used with the INITiate command for totalize measurements. When FETCh? is executed on a TOTalize count, the count is not reset allowing cumulative counting. Perform a fetch with the following command:

FETC*n*? (*n* = channel number)

The reading is transferred from mainframe/command module memory to the output buffer. The measurement result is then available to be transferred into the computer.

Stopping a Measurement The ABORt command stops a measurement in process (Counter in idle state). Perform an abort with the following command:

ABOR*n* (*n* = channel number)

Note Sending a new measurement command will also abort a measurement in progress.

Selecting Range and Resolution

When using MEASure and CONFIgure to perform frequency, period, and ratio measurements, it is possible to enter the range or “expected value” of the measurement and the desired resolution. If these values are not specified, AUTO range with 5 digits of resolution is used.

Range (expected value) Range, or the "expected value" of the signal to be measured, is an optional parameter of the MEAS and CONF commands. If range is not specified, the counter operates in the "AUTO" range mode (default mode). When in AUTO, the counter makes a measurement first using the default setting of aperture time or number of periods (2 msec for frequency measurements, 2 cycles for period and ratio measurements). From this measurement it selects the measurement technique and aperture time or number of periods to perform the measurement to the required resolution. More information

about aperture time and number of periods is presented in the section titled “Selecting Aperture Time and Number of Periods” on page 47.

Resolution

Resolution is the smallest change in the measurement that can be discerned. The finer the resolution, the longer the aperture time or number of periods. Five digits of resolution is selected at turn-on or reset.

Setting the Range and Resolution

You can speed the measurement cycle by specifying the range and resolution of the measurement using the MEASure or CONFigure command. This allows the counter to set the measurement technique and the required aperture time or number of periods for that signal without first making a "sample" measurement.

Note

Asking for more resolution generally results in slower measurements.

Use the MEASure or CONFigure commands to specify range and resolution as follows:

MEAS*n*:*xxxx*? *z*, *y* (*n* = channel number; *xxxx* = FREQ, RAT, or PER; *z* = expected value in Hz (or seconds); *y* = resolution in Hz (or seconds))

CONF*n*:*xxxx* *z*, *y* (*n* = channel number; *xxxx* = FREQ, RAT, or PER; *z* = expected value in Hz (or seconds); *y* = resolution in Hz (or seconds))

For example, to set the range to 1 MHz, and resolution to 10 Hz for a frequency measurement on channel 1 using the MEASure command (resulting in a 5 digit measurement), execute:

```
MEAS:FREQ? 1E6, 10
```

Note

By specifying the resolution in a MEASure or CONFigure command, the counter automatically selects the proper function (SENS*n*:FUNC) and the aperture time (SENS*n*:FREQ:APER) or number of periods (SENS*n*:PER:NPER or SENS*n*:RAT:NPER) required to obtain that resolution. If resolution is specified, range (expected value) must also be specified.

Selecting Aperture Time and Number of Periods

When using SENSE:FUNCTION to perform frequency and period measurements, it is possible to enter the aperture time (for frequency), or the number of periods (for period).

Note By specifying the resolution in a MEASure or CONFIgure command, the Counter automatically selects the aperture time or number of periods required to obtain that resolution. Explicitly selecting aperture time or number of periods using SENS*n*:FREQ:APER, SENS*n*:PER:NPER, or SENS*n*:RAT:NPER is not required and sometimes ignored by the Counter.

Aperture Time (Gate Time)

Aperture time is the period of time the Counter samples the input signal to make a frequency measurement. This period of time directly determines how much resolution you can obtain with a frequency measurement.

Setting the Aperture Time

Aperture time can be specified by using the SENSE command. Setting the aperture time selects a specific resolution.

Aperture time can be set from 2 mS to 65.536 seconds in 16 binary steps. If you specify an aperture time that is not one of the binary steps, the next highest binary step is used. For example, if you specify 10 mS, aperture time is set to 16 mS. 2mS is selected at turn-on or reset. Table 4-2 shows resolution versus aperture time for the 16 different steps available.

Table 4-2. Resolution versus Aperture Time

Aperture Time in msec	Resolution in Hertz	Min Frequency for 6 digits of Resolution	Min Frequency for 5 digits of Resolution	Min Frequency for 4 digits of Resolution	Min Frequency for 3 digits of Resolution
2	500 Hz				500 kHz
4	250 Hz			2.5 MHz	250 kHz
8	125 Hz			1.25 MHz	125 kHz
16	62.5 Hz			625 kHz	62.5 kHz
32	31.25 Hz		3.1 MHz	313 kHz	31.3 kHz
64	15.625 Hz		1.5 MHz	156 kHz	15.6 kHz
128	7.813 Hz		781 kHz	78.1 kHz	7.81 kHz
256	3.977 Hz	4.0 MHz	398 kHz	39.8 kHz	3.98 kHz
512	1.953 Hz	1.9 MHz	195 kHz	19.5 kHz	1.95 kHz
1024	.977 Hz	977 kHz	98 kHz	9.77 kHz	977 Hz
2048	.488 Hz	488 kHz	40 kHz	4.88 kHz	488 Hz
4096	.244 Hz	244 kHz	24 kHz	2.44 kHz	244 Hz
8192	.122 Hz	122 kHz	12 kHz	1.22 kHz	122 Hz
16384	.061 Hz	61 kHz	6 kHz	610 Hz	61 Hz
32768	.031 Hz	30 kHz	3 kHz	310 Hz	31 Hz
65536	.015 Hz	15 kHz	1.5 kHz	150 Hz	15 Hz

You set aperture time with the command SENS*n*:FREQ:APER *xxx* (*xxx* = the aperture time in seconds)

Number of Periods

The number of periods is the number of cycles that the Counter samples the input signal to make a period or ratio measurement. This period of time directly determines how much resolution you can obtain with these measurement.

Setting the Number of Periods

The number of periods can be specified by using the SENSE command. Setting the number of periods selects a specific resolution.

Number of periods can be set from 2 to 65,536 cycles in 16 binary steps. If you specify a number of periods that is not one of the binary steps, the next highest binary step is used. For example, if you specify 10, number of periods is set to 16. 2 cycles are selected at turn-on or reset. Table 4-3 shows resolution versus number of periods for the 16 different steps available.

Table 4-3. Resolution versus Number of Periods

Number of Periods to Average	Resolution in Seconds	Max Frequency for 6 digits of Resolution	Max Frequency for 5 digits of Resolution	Max Frequency for 4 digits of Resolution	Max Frequency for 3 digits of Resolution
2	100 nsec	10 Hz	100 Hz	1 kHz	10 kHz
4	50 nsec	20 Hz	200 Hz	2 kHz	20 kHz
8	25 nsec	40 Hz	400 Hz	4 kHz	40 kHz
16	12.5 nsec	80 Hz	800 Hz	8 kHz	80 kHz
32	6.25 nsec	160 Hz	1.6 kHz	16 kHz	160 kHz
64	3.13 nsec	320 Hz	3.2 kHz	32 kHz	320 kHz
128	1.56 nsec	640 Hz	6.4 kHz	64 kHz	640 kHz
256	781 psec	1.28 kHz	12.8 kHz	128 kHz	1.28 MHz
512	390 psec	2.56 kHz	25.6 kHz	256 kHz	2.56 MHz
1024	195 psec	5.12 kHz	51.2 kHz	512 kHz	
2048	97.6 psec	10.24 kHz	102.4 kHz	1.024 MHz	
4096	488.8 psec	20.48 kHz	204.8 kHz	2.048 MHz	
8192	24.4 psec	40.96 kHz	409.6 kHz		
16384	12.2 psec	81.92 kHz	819.2 kHz		
32768	6.10 psec	162.84 kHz	1.63 MHz		
65536	3.05 psec	326.78 kHz	3.27 MHz		

You set number of periods with the command SENS n :PER:NPER xxx (xxx = the number of periods)

Selecting Trigger Source

The Counter operates in two states as shown in Figure 4-2.

1. **Idle state.** Configuration of the Counter and its trigger system occur while in the idle state.
2. **Wait-for-trigger state.** The Counter is placed in the wait-for-trigger state when a measurement is initiated.

A measurement is made (measurement action) when the Counter is placed in the wait-for-trigger state and a trigger is received. The trigger has several sources which are discussed later in this section. All measurements made by the Counter complete except totalizing events (TOTALize function). On completion, of a measurement, the Counter returns to the idle state. The TOTALize function does not complete which allows it to totalize events until the measurement action is aborted or the channel is reconfigured returning the Counter to the idle state.

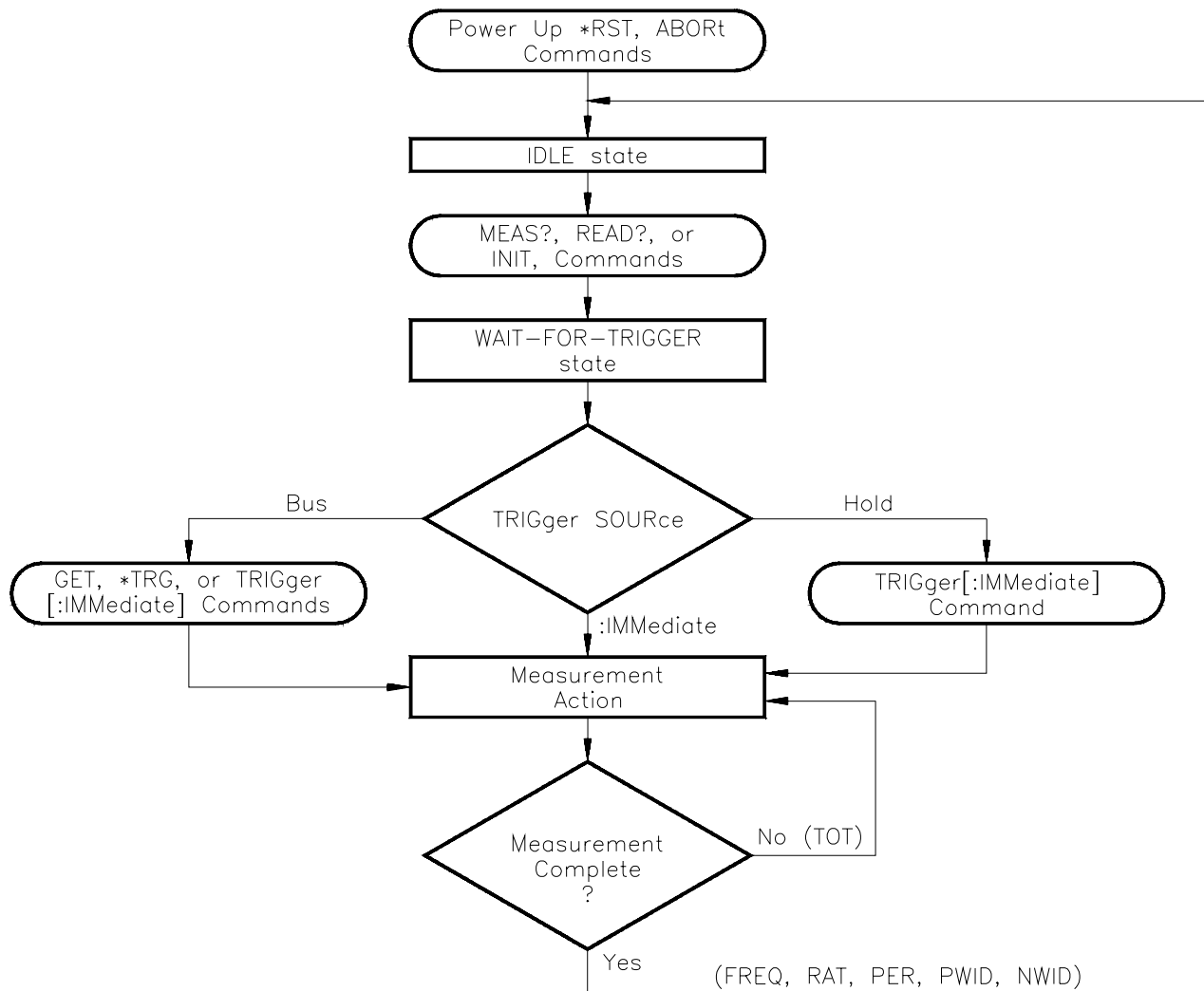

Figure 4-2. Counter Trigger System

Trigger System Commands

This section describes the commands used to set up the trigger system.

Using TRIGger:SOURce

The Counter operates from one of the three trigger sources listed below. These sources are the parameters of the TRIGger:SOURce BUS | HOLD | IMM command. A measurement will not be made until a trigger from the specified source occurs.

- **BUS** - trigger source is the HP-IB group execute trigger (GET) or the system *TRG command, or the TRIGger[:IMMEDIATE] command.
- **HOLD** - suspends triggering. Once set, the measurement can only be triggered with the TRIGger[:IMMEDIATE] command.
- **IMMEDIATE** - an internal trigger signal is always present. Initiating the measurement causes it to be triggered.

The trigger source is set with the following command:

```
TRIG:SOUR <source> (source = BUS, HOLD, or IMM)
```

Note

Do not confuse the two levels of commands containing the IMMEDIATE parameter used in triggering. TRIGger[:IMMEDIATE] is used to cause a single trigger cycle after the trigger system has been disabled (see the TRIGger:SOURce HOLD | BUS commands). TRIGger:SOURce IMMEDIATE bypasses the trigger system so that initiating a measurement causes it to immediately occur (see the TRIGger:SOURce IMMEDIATE command).

Using TRIGger[:IMMEDIATE]

Sending the TRIGger[:IMMEDIATE] command causes one trigger cycle to occur immediately. This command is used when the TRIGger:SOURce is HOLD or BUS and a measurement has been initiated with the INITiate command. If the trigger system has not been disabled (TRIGger:SOURce HOLD | BUS command) and the Counter is not in the wait-for-trigger state (INITiate command), an error will be generated. Correct use of TRIGger[:IMMEDIATE] is shown below:

```
TRIG:SOUR HOLD (or TRIG:SOUR BUS)
INIT
TRIG:IMM (or TRIG)
```

Synchronizing Instruments

This example shows how you synchronize instruments. In this example, a multiplexer switches a signal to be measured by the counter. This program verifies that the switching is complete before the counter begins a measurement. For this example, the counter is at address 70906 and the multiplexer is at 70914.

```
10    !Close channel 101 and request confirmation that the channel is closed.
20    OUTPUT 70914;"CLOSE (@101);*OPC?"
30    !Read confirmation.
40    ENTER 70914;A
50    !At this point the channel is closed and the measurement can be made.
60    OUTPUT 70906;"MEAS:FREQ?"
70    ENTER 70906;Meas_value
80    END
```

Synchronizing the Counter with a Computer

This is an example of how an HP 9000 Series 200/300 computer can monitor the Counter to determine when measurement data is available. The computer can perform other functions while waiting for a Counter measurement. When a measurement completes and data is available, the "Message Available" bit (MAV - bit number 4 in the Status Register) is set true. The computer recognizes this bit set true, stops its current activity, and enters the data.

```
10    !Clear and reset the counter. Unmask the Message Available (MAV)
20    !bit in the Status Register (bit 4).
30    !
40    OUTPUT 70906;"*CLS"
50    OUTPUT 70906;"*RST"
60    OUTPUT 70906;"*SRE 16"
70    !
80    !Configure the counter for a period measurement, make the
90    !measurement, and transfer the data to the output buffer.
100   OUTPUT 70906;"CONF:PER"
110   OUTPUT 70906;"INIT"
120   OUTPUT 70906;"FETC?"
130   !
140   !Monitor the message available bit. Have the computer perform
150   !another function (e.g. display a message) until the bit indicating a
160   !message is available is set. Enter and display the measurement.
170   !
180   WHILE NOT BIT (SPOLL(70906),4)
190       DISP "WAITING FOR DATA"
200       WAIT 1
210       DISP " "
220       WAIT 1
230   END WHILE
240   ENTER 70906;A
250   PRINT A
260   END
```

Checking for Errors

There are two general approaches to error checking. The simplest, but most time consuming, is to ask the instrument whether there are errors at every step of the measurement process. This is called "polling" and is illustrated in the program segment below.

```
10   OUTPUT 70906;"INP:COUP DC;;SYST:ERR?"
20   ENTER 70906;Err_num
30   IF Err_num <>0 THEN
40       PRINT "Error";Err_num;"occurred"
50       STOP
60   END IF
70   . . . (program continues)
```

The other approach involves the use of interrupts. The following program is a method of checking for errors using interrupts as you program the Counter. The program monitors the Counter's Standard Event Status Register for an error condition. If no errors occur, the Counter functions as programmed. If errors do occur, the Counter interrupts the computer and the error codes and messages are read from the Counter's error queue. This approach requires less overhead but is more complex.

The computer commands shown are for an HP 9000 Series 200/300 computer running HP BASIC and controlling the Counter over HP-IB.

```
10   !Call computer subprogram "Errmsg" if a counter programming error
20   !occurs. Enable the computer to respond to an interrupt from the
25   !counter.
30   !
40   ON INTR 7 CALL Errmsg
50   ENABLE INTR 7;2
60   !
70   !Unmask the Event Status bit in the counter's Status Register. Unmask
80   !the counter error conditions in its Standard Event Status Register.
90   !
100  OUTPUT 70906;"*SRE 32"
110  OUTPUT 70906;"*ESE 60"
120  !
130  !At this point, the counter is programmed for the intended application.
140  !
150  OUTPUT 70906;" ...
160  OUTPUT 70906;" ...
170  !
180  ENTER 70906; ...
190  PRINT ...
200  END
210  !
220  !When an error occurs, clear the counter to regain control. Execute
230  !a Serial Poll to clear the service request bit in the Status Register.
240  !Read all error messages in the counter error queue. Clear all
250  !bits in the counter Standard Event Status Register.
260  !
270  SUB Errmsg
280  DIM Message$(256)
```

```

290 CLEAR 70906
300 B =SPOLL(70906)
310 REPEAT
320     OUTPUT 70906;"SYS:ERR?"
330     ENTER 70906;Code,Message$
340     PRINT Code,Message$
350 UNTIL Code=0
360 OUTPUT 70906;"*CLS"
370 STOP
380 SUBEND

```

Comments

1. If you have an HP 75000 Series B mainframe with a front panel keyboard, errors can be monitored by selecting "Monitor" from the counter menu. If errors occur when the program executes, the "err" annunciator will appear. Entering SYST:ERR? repeatedly from the keyboard reads all of the messages in the error queue.
2. The *HP 75000 Series B Mainframe User's Manual* contains detailed information on the Status and Standard Event Status registers.

Checking for Overflow

In the section "Checking for Errors", it is shown that error checking by polling was impractical because of the high overhead. It is also unnecessary since once a program is correct, errors should not occur. For overflow checking, it is practical to poll since overflows are signal dependent and should be checked after a measurement. You only need to check for overflow by polling after a MEAS?, READ?, or FETCh? command. These are the only commands that put the measurement data in the output buffer for entry by the computer. Because of this you have less overhead in polling for an overflow condition.

The following example illustrates overflow checking after a measurement by polling.

```

10 OUTPUT 70906;"MEAS:PER?"
20 !Makes the measurement. Line 60 queries the status questionable
30 !data/signal register to see if the overflow bit was set (a 0 returned
40 !indicates no overflow).
50 ENTER 70906;Meas_data
60 OUTPUT 70906;"STAT:QUES?"
70 ENTER 70906;Ques_data
80 IF Ques_data <>0 THEN
90     PRINT "Overflow occurred"
100 STOP
110 END IF
120 ... (program continues)

```

Checking for Overflow Using an Interrupt

The following program is a method of checking for overflow conditions using an interrupt. The program monitors bit 3 called QUE in the Counter Status Register for questionable data (see the diagram in the STATUS subsystem command in Chapter 5). The Status Register bit 3 is set true when an overflow occurs. When this bit goes true, the Counter interrupts the computer and the overflow channel is identified by reading the Questionable Data/Signal Register.

The computer commands shown are for an HP 9000 Series 200/300 computer running HP BASIC and controlling the Counter over HP-IB.

```
10      !Call the computer subprogram "Ovrflo" if a counter measurement
20      !overflow occurs. Enable the computer to respond to an interrupt
30      !from the counter.
40      !
50      ON INTR 7 CALL Ovrflo
60      ENABLE INTR 7;2
70      !
80      !Unmask the Questionable Data bit in the counter's Status Register.
90      !Unmask the counter questionable data bits 9, 10, and 11
100     !(channels 1, 2, and 3) in the Questionable Data/Signal Register.
110     !
120     OUTPUT 70906;"*SRE 8"
130     OUTPUT 70906;"STAT:QUES:ENAB 3584"
140     !
150     !Program the counter for the application.
-
-
-
400     !When an overflow occurs, clear the counter to regain control.
410     !Execute a Serial Poll to clear the questionable bit in the Status
420     !Register. Read the Questionable Data/Signal Event Register to
430     !see which channel reported the overflow condition.
440     !
450     SUB  Ovrflo
460     Integer=Bitvalue
470     CLEAR 70906
480     B=SPOLL (70906)
490     OUTPUT 70906;"STAT:QUES?"
500     ENTER 70906;Bitvalue
510     PRINT Bitvalue
520     OUTPUT 70906;"*CLS"
530     STOP
540     SUBEND
```

Querying the Counter

This section summarizes the query commands you can use to determine the configuration or state of the Counter. Send the command following the item you want to query. All commands end with the “?” which puts the data into the output buffer where your computer can retrieve it.

Aperture time:	SENS n :FREQ:APER? (n = channel number)
Configured measurement:	CONF n ? (n = channel number)
Display monitor channel:	DISP:MON:CHAN?
Display monitor state:	DISP:MON:STAT?
Event level:	SENS n :EVEN:LEV? (n = channel number)
Event slope:	SENS n :EVEN:SLOP? (n = channel number)
Function:	SENS n :FUNC? (n = channel number)
Input attenuation:	INP:ATT?
Input coupling:	INP:COUP?
Input filter state:	INP:FILT[:LPAS]:STAT?
Input impedance:	INP:IMP?
Number of periods:	SENS n :PER:NPER? (n = channel number)
Status questionable condition:	STAT:QUES:COND?
Status questionable enable:	STAT:QUES:ENAB?
Status questionable event:	STAT:QUES[:EVEN]?
System error:	SYST:ERR?
Trigger source:	TRIG:SOUR?

Chapter 5 HP E1333A Universal Counter Command Reference

Using This Chapter

This chapter describes Standard Commands for Programmable Instruments (SCPI) commands and summarizes IEEE 488.2 Common (*) Commands applicable to the HP E1333A 3-Channel Universal Counter. This chapter contains the following sections:

- Command Types Page 57
- SCPI Command Reference Page 60
- IEEE 488.2 Common Commands Page 101
- Command Quick Reference. Page 102

Command Types

Commands are separated into two types: IEEE 488.2 Common Commands and SCPI Commands.

Common Command Format

The IEEE 488.2 standard defines the Common Commands that perform functions like reset, self-test, status byte query, etc. Common Commands are four or five characters in length, always begin with the asterisk character (*), and may include one or more parameters. The command keyword is separated from the first parameter by a space character. Some examples of Common Commands are shown below:

*RST *ESR 32 *STB?

SCPI Command Format

The SCPI commands perform functions like closing switches, making measurements, and querying instrument states or retrieving data. A subsystem command structure is a hierarchical structure that usually consists of a top level (or root) command, one or more lower level commands, and their parameters. The following example shows part of a typical subsystem:

```
[ROUTe:]  
  CLOSe <channel_list>  
  SCAN <channel_list>  
    :MODE VOLT
```

[ROUTe:] is the root command, CLOSe and SCAN are second-level commands with parameters, and MODE is a third-level command with the parameter VOLT.

Command Separator A colon (:) always separates one command from the next lower level command as shown below:

ROUTe:SCAN:MODE VOLT

Colons separate the root command from the second-level command (ROUTe:SCAN) and the second-level from the third-level (SCAN:MODE VOLT). The parameters of a command are separated from the command by a blank space.

Abbreviated Commands The command syntax shows most commands as a mixture of upper and lower case letters. The upper case letters indicate the abbreviated spelling for the command. For shorter program lines, send the abbreviated form. For better program readability, you may send the entire command. The instrument will accept either the abbreviated form or the entire command.

For example, if the command syntax shows MEASure, then MEAS and MEASURE are both acceptable forms. Other forms of MEASure, such as MEASU or MEASUR will generate an error. You may use upper or lower case letters. Therefore, MEASURE, measure, and MeAsUrE are all acceptable.

Command keywords can be entered in their full form, as shown above, or can be entered in their short form. In this manual, the entry required in short form commands is always capitalized. The short form is generally used for examples in this manual.

Implied Commands Implied commands are those which appear in square brackets ([]) in the command syntax. (Note that the brackets are not part of the command and are not sent to the instrument.) Suppose you send a second level command but do not send the preceding implied command. In this case, the instrument assumes you intend to use the implied command and it responds as if you had sent it. Examine this excerpt from the [SENSE:] subsystem shown below:

```
[SENSE:]  
  EVENT  
    :LEVel <number | MIN | MAX | DEF>  
    :LEVel?  
    :SLOPe <POSitive | NEGative>  
    :SLOPe?
```

The root command [SENSE:] is an implied command. To set the instrument's trigger level to +1.5, you can send either of the following command statements:

SENS:EVEN:LEV 1.5 *or* EVEN:LEV 1.5

Implied Channel Some commands contain channel numbers in square brackets (for example, [1|2|3]). The brackets indicate declaring a channel number in the command is optional. If a channel number is not specified, channel number 1 is implied.

Parameters **Parameter Types.** The following table contains explanations and examples of parameter types you might see later in this chapter.

Parameter Type	Explanations and Examples
Numeric	Accepts all commonly used decimal representations of numbers including optional signs, decimal points, and scientific notation. 123, 123E2, -123, -1.23E2, .123, 1.23E-2, 1.23000E-01. Special cases include MIN, MAX, and DEF. MIN selects minimum value available, MAX selects maximum value available, and DEF selects default or reset value.
Boolean	Represents a single binary condition that is either true or false. 1 or ON; 0 or OFF.
Discrete	Selects from a finite number of values. These parameters use mnemonics to represent each valid setting. An example is the TRIGger:SOURce <source> command where <i>source</i> can be BUS, HOLD, or IMMEDIATE.

Optional Parameters. Parameters shown within square brackets ([]) are optional parameters. (Note that the brackets are not part of the command and are not sent to the instrument.) If you do not specify a value for an optional parameter, the instrument chooses a default value. For example, consider the EVENT:LEVel? [<MIN | MAX | DEF>] command. If you send the command without specifying a parameter, the present EVENT:LEVel value is returned. If you send the MIN parameter, the command returns the minimum count available. If you send the MAX parameter, the command returns the maximum count available. Be sure to place a space between the command and the parameter.

Query Parameters. All selectable numeric parameters can be queried to return the minimum, maximum, or default values they are capable of being set to by sending a MIN, MAX, or DEF optional parameter after the "?". For example, to query the maximum aperture time for frequency measurements, send the following:

```
FREQ:APER? MAX
```

Linking Commands

Linking IEEE 488.2 Common Commands with SCPI Commands.

Use a semicolon between the commands. For example:

```
*RST;CONF2:PER or TRIG:SOUR HOLD;*TRG
```

Linking Multiple SCPI Commands. Use both a semicolon and a colon between the commands. For example:

```
EVEN:LEV 1;;TRIG:SOUR HOLD
```

SCPI Command Reference

This section describes the Standard Commands for Programmable Instruments (SCPI) commands for the HP E1333A 3-Channel Universal Counter. Commands are listed alphabetically by subsystem and alphabetically within each subsystem.

ABORt

The **ABORt** command terminates a measurement by controlling the state of a specific channel's trigger system. Executing the ABORt command changes the trigger system from the "wait-for-trigger" state to the "idle" state.

Subsystem Syntax ABORt[1|2|3]

Parameters Only one channel number can be specified in the command. The channel number defaults to channel 1 if a channel number is not specified.

- Comments**
- ABORt performs the opposite function of the INITiate command. INITiate enables the trigger system, while ABORt disables it.
 - When TRIGger:SOURce BUS is selected, ABORt returns the counter to the idle state. When *TRG is executed, the "Trigger Ignored" error is generated.
 - When TRIGger:SOURce HOLD is selected, ABORt returns the counter to the idle state and subsequent single triggers (TRIGger:IMMediate) are ignored.
 - **Implied ABORt:** In general, it is not necessary to abort a measurement using the ABORt command. Selecting a new function or initiating a new measurement will perform an implied abort.

Example **Aborting a Measurement**

CONF2:PER	<i>Channel 2 function is period.</i>
TRIG:SOUR HOLD	<i>Suspend triggering.</i>
INIT2	<i>Channel 2 go to wait-for-trigger state.</i>
.	
.	
ABOR2	<i>Channel 2 go to idle state.</i>

CONFigure

The CONFigure command subsystem sets up the Counter to perform a specified measurement, either in AUTO range or on a manually entered range, but *does not* perform the actual measurement. Use the INITiate and FETCh? or READ? commands to initiate and read the measurement.

Subsystem Syntax

```
CONFigure[1|2|3]
:FREquency [<range>[,<resolution>]]
:NWIDth [<range>[,<resolution>]]
:PERiod [<range>[,<resolution>]]
:PWIDth [<range>[,<resolution>]]
:RATio [<range>[,<resolution>]]
:TINTerval [<range>[,<resolution>]]
:TOTALize*
```

Comments

- ***Range and Resolution Ignored:** *Range* and *resolution* parameters are accepted but ignored for TOTALize measurements.
- **Specifying Range and Resolution:** If the optional parameters are to be used, *range* must be specified if a value for *resolution* is entered. You cannot enter a value for *resolution* without a preceding *range* value.
- **Manual Range:** If the optional parameters *range* and *resolution* are specified, the Counter makes the measurement using the values entered. A slightly faster measurement is made when range is specified since a sample measurement to determine the correct range is unnecessary.
- **Auto Range:** If the optional parameters *range* and *resolution* are not entered, the input signal is sampled to determine the proper *range* setting. *Resolution* is set for a default *resolution* of 5 digits (4 digits for RATio).
- **CONFigure and MEASure versus SENSE:** Most measurements can be performed using one of these three subsystems, and each has advantages and disadvantages over the other. The differences in the commands are:

The CONFigure command can be used for all measurements. The CONFigure command only configures a channel for a specific function, and does not perform the measurement. Use of additional commands (READ? or INIT/FETC?) to perform the measurement and read the results is necessary. The choice of manual or AUTO ranging for frequency and period functions is provided through the use of optional parameters.

The MEASure command can be used for all measurements except TOTALize. The MEASure command configures a channel for a specific function, performs the measurement, and returns the result to the output buffer. The choice of manual or AUTO ranging for frequency and period functions is provided through the use of optional parameters.

Both CONFIGure and MEASure commands are instrument independent and can be used in other instruments to perform similar functions. Use these commands when the portability of instrument syntax is important.

The SENSE subsystem can be used for all measurements. The SENSE:FUNCTION command only configures a channel for a specific function and does not perform the measurement. Use of additional commands (READ? or INIT/FETC?) to perform the measurement and store the results is necessary. Only manual ranging for frequency and period functions is provided, and these parameters may be entered using an additional command (SENS:FREQ:APER or SENS:PER:NPER).

The SENSE commands are instrument dependent and may behave differently in other instruments. These commands should be used when direct control over the measurement is important.

:FREQUENCY CONFIGure[1|2|3]:FREQUENCY [<range>[,<resolution>]] configures the Counter for the frequency measurement function. This command does not initiate the measurement process.

Parameters

Parameter Name	Parameter Type	Range of Values	Default Value
<i>range</i>	Numeric or Discrete	29.1E-3 to 100E6 Hz (ch 1 & 2) 75E6 to 1E9 Hz (ch 3) MIN MAX AUTO	AUTO
<i>resolution</i>	Numeric or Discrete	4.2E-15 to 500 Hz MIN MAX	5 digits

Comments

- **Channel Selection:** Select only one channel at a time.
- **Type of Signal Measured:** Signals must be periodic for the frequency function.
- **Entering Range:** *Range* can be entered as a number in Hz from 0.002 Hz to 100 MHz for channels 1 and 2. For channel 3, *range* can be entered as a number in Hz from 75 MHz to 1 GHz. AUTO range is selected when *range* is not specified. Refer to the section titled “Selecting Range and Resolution” on page 46 for more information.
- **Entering Resolution:** *Resolution* is entered as a number from 4.2E-15 Hz to 500 Hz. Entries up to 1E8 for channels 1 and 2 and 1E9 for channel 3 will be accepted. *Resolution* is automatically set for 5 digits of resolution (4 digits for RATIo function) by not entering a value for the optional *resolution* parameter. If *resolution* is entered, *range* must also be entered. Refer to the section titled “Selecting Range and Resolution” on page 46 for more information.
- **Overflow Indication:** Overflow is detected by querying the Questionable Data/Signal Register (see the STATus subsystem later in this chapter).

Example Making Frequency Measurements

CONF:FREQ 1E6,10

Channel 1; function is FREQuency; range is 1 MHz; resolution is 10 Hz.

READ?

Place counter in wait-for-trigger state; take reading.

:NWIDth **CONF**igure[1|2]:**NWID**th [**<range>**[,**<resolution>**]] configures the Counter for the negative pulse width measurement function on channel 1 or 2 (channel 1 is the default). This command does not initiate the measurement process.

Parameters **Entering Range:** Measurement *range* is from 200 nsec to 6871 seconds.

Entering Resolution: *Resolution* can be entered as a number in seconds from 0.781 nsec (100 nsec/128) to 100 nsec. Entries up to 6871 seconds will be accepted. *Resolution* is automatically set to 5 digits by not entering values for *range* and *resolution*. If *resolution* is entered, *range* must also be entered. Refer to the section titled “Selecting Range and Resolution” on page 46 for more information.

Comments

- **Channel Selection:** Select only one channel at a time. Channel 3 cannot make pulse width measurements.
- **Edge Select:** Negative pulse width is measured from the falling edge to the rising edge. The command will hang until the second edge is detected. If none is detected within 6871 seconds, an overflow occurs (see next item).
- **Overflow Indication:** Overflow is detected by reading the Questionable Data/Signal Register (see the STATus subsystem later in this chapter).

Example Making Negative Pulse Width Measurements

CONF:NWID

Channel 1; function is negative pulse width.

READ?

Place counter in wait-for-trigger state; take readings.

:PERiod **CONFigure**[1|2]:**PERiod** [*<range>*[,*<resolution>*]] configures the Counter for the period average measurement function on channel 1 or 2 (channel 1 is the default). This command does not initiate the measurement process.

Parameters

Parameter Name	Parameter Type	Range of Values	Default Value
<i>range</i>	Numeric	10E-9 to 6871 MIN MAX AUTO	AUTO
<i>resolution</i>	Numeric	1.5E-18 to .002 sec MIN MAX DEF	5 digits

Comments

- **Channel Selection:** Select only one channel at a time. Channel 3 cannot make period measurements.
- **Type of Signal Measured:** Signals must be periodic for the period function.
- **Entering Range:** *Range* is entered as a number in seconds from 10 nsec to 6871 seconds. The counter uses AUTO range when the *range* parameter is not specified. Refer to the section titled “Selecting Range and Resolution” on page 46 for more information.
- **Entering Resolution:** *Resolution* is entered as a number in seconds from 1.5E-18 to .002 seconds. Entries up to 6871 seconds will be accepted. *Resolution* is automatically set to 5 digits if *range* and *resolution* are not specified in the command. If *resolution* is entered, it must be preceded by a *range* value. Refer to the section titled “Selecting Range and Resolution” on page 46 for more information.
- **Overflow Indication:** Overflow can be detected by reading the Questionable Data/Signal Register (see the STATus subsystem later in this chapter).

Example Making Period Measurements

CONF:PER 1E-3,1E-6

*Function is period;
range is 1 mS;
resolution is 1 μS.*

INIT

*Store readings in mainframe
memory; trigger source is
IMMediate by default.*

FETC?

Place readings in output buffer.

enter statement

Enter readings into computer.

:PWIDth **CONFigure[1|2]:PWIDth [*<range>*[,*<resolution>*]]** configures the Counter for the positive pulse width measurement function on channel 1 or 2 (channel 1 is the default). This command does not initiate the measurement process.

Parameters **Entering Range:** Measurement *range* is from 200 nsec to 6871 seconds.

Entering Resolution: *Resolution* can be entered as a number in seconds from 0.781 nsec to 100 nsec. Entries up to 6871 seconds will be accepted. *Resolution* is automatically set to 5 digits by not entering values for *range* and *resolution*. If *resolution* is entered, *range* must also be entered. Refer to the section titled “Selecting Range and Resolution” on page 46 for more information.

- Comments**
- **Channel Selection:** Select only one channel at a time. Channel 3 cannot make pulse width measurements.
 - **Edge Select:** Positive pulse width is measured from the rising edge to the falling edge. The command will hang until the second edge is detected. If none is detected within 6871 seconds, an overflow occurs (see next item).
 - **Overflow Indication:** Overflow is detected by reading the Questionable Data/Signal Register (see the STATus subsystem later in this chapter).

Example **Making Positive Pulse Width Measurements**

CONF:PWID

Channel 1; function is positive pulse width.

READ?

Place counter in wait-for-trigger state; take readings.

:RATio **CONF**[1|2]:**RATio** [*<range>*[,*<resolution>*]] configures the Counter for the ratio measurement function. A ratio measurement requires both channels 1 and 2 with the specified channel as the numerator of the ratio.

Parameters

Parameter Name	Parameter Type	Range of Values	Default Value
<i>range</i>	Numeric	9.3E-10 to 1E9	AUTO
<i>resolution</i>	Numeric	1.35E-20 to .0156 (1/64)	4 digits

Comments

- **Channel Selection:** Select only one channel at a time. Channels 1 and 2 are used for ratio measurements and the channel selected is the numerator of the ratio. For example, if channel 2 is specified (CONF2:RAT), the result will be the ratio of channel 2/channel 1.
- **Type of Signals Measured:** Signals must be periodic for the ratio function.
- **Entering Range:** *Range* is entered as a number from 9.3E-10 to 1E9. The counter uses AUTO range when the *range* parameter is not specified. Refer to the section titled “Selecting Range and Resolution” on page 46 for more information.
- **Entering Resolution:** *Resolution* is entered as a number from 1.35E-20 to 0.0156. 4 digits of resolution is automatically set if *resolution* is not specified in the command. Refer to the section titled “Selecting Range and Resolution” on page 46 for more information.
- **Overflow Indication:** Overflow is detected by reading the Questionable Data/Signal Register (see the STATus subsystem later in this chapter).

Example Making Ratio Measurements (ratio of Channel 1 over Channel 2)

CONF:RAT

Function is RATio (ch1/ch2).

READ?

Place counter in wait-for-trigger state; make measurement; put data in the output buffer.

enter statement

Enter readings into computer.

:TINterval **CONFigure[1|2]:TINterval [<range>[,<resolution>]]** configures the Counter for the time interval measurement function on channel 1 or 2 (channel 1 is the default). This command does not initiate the measurement process.

Parameters This command ignores the *range* parameter but will accept the *resolution* parameter if a numeric *range* parameter precedes it. You must send a value for the *range* parameter for *resolution* to be accepted even though it is ignored.

Parameter Name	Parameter Type	Range of Values	Default Value
<i>range</i>	Numeric	200E-9 to 6871	AUTO
<i>resolution</i>	Numeric	1E-7 to 1E-7/128 (7.81E-10)	100 nsec

- Comments**
- **Channel Selection:** Select only one channel at a time. Channel 3 cannot make time interval measurements.
 - **Specifying the Channel:** The channel declared in the command is the channel the time interval measurement begins with. For example, if channel 2 is specified (CONF2:TINT), the result will be the time interval from the event at channel 2 to the event at channel 1.
 - **Start and Stop Edges:** The edges of both the start and stop channels can be selected using the SENSE:SLOPe command. Unless changed, the measurement will be performed using the presently selected slope.
 - **Entering Range:** The *range* parameter is ignored for time interval measurements but must be entered if the *resolution* parameter is entered.
 - **Entering Resolution:** *Resolution* is entered as a number from 1E-7 to 1E-7/128. 100 nsec default resolution is used if a *resolution* is not specified in the command. Refer to the section titled “Selecting Range and Resolution” on page 46 for more information.
 - **Overflow Indication:** Overflow is detected by reading the Questionable Data/Signal Register (see the STATus subsystem later in this chapter).

Example Making Time Interval Measurements (Channel 1 to Channel 2)

CONF:TINT	<i>Function is TINT.</i>
READ?	<i>Place counter in wait-for-trigger state; make measurement; put data in the output buffer.</i>
enter statement	<i>Enter readings into computer.</i>

:TOTalize **CONFigure[1|2]:TOTalize** configures the Counter for the totalize function but does not initiate the measurement procedure. This function allows you to count events on either channel 1 or channel 2, or to simultaneously count events on channels 1 and 2. Once the measurement is started, the totalize function remains active until the channel is reconfigured to another function.

Parameters There are no parameters for the totalize function. However, *range* and *resolution* parameters are accepted by the command but ignored.

- Comments**
- **Continuous Counting:** This function continues counting events for the specified channel until the channel is reconfigured for another function.
 - **Reading Measurement Results:** The totalize measurement is started with the **INITiate** command which resets the counter. Measurement results are read using the **FETCh?** command which reads the current count without resetting the counter or interrupting the measurement. Do not use the **READ?** command for totalize measurements.
 - **Overflow Indication:** Overflow is detected by using the Questionable Data/Signal Register (see the **STATus** subsystem later in this chapter).
 - **Range and Resolution:** Values for *range* and *resolution* can be entered, but are ignored. Measurement *range* is up to 6.87E10 counts.
 - **Timing:** When performing totalizing measurements, the Counter must be given sufficient time to configure and initiate the measurement before the first event is received.

Example Counting Events with Totalize

CONF:TOT	<i>Sets channel 1 to the TOTalize function.</i>
INIT	<i>Resets counter and starts the counting of events.</i>
.	
.	<i>Count accumulates.</i>
.	
FETCh?	<i>Read the count "on-the-fly"; store count in output buffer.</i>
enter statement	<i>Enter readings into computer.</i>

CONFigure?

CONFigure? returns the function, range, and resolution that the specified channel was configured for with the last CONFigure or MEASure command.

Subsystem Syntax CONFigure[1|2|3]?

Parameters Select one channel for the command (1, 2, or 3). If a channel is not specified, the command acts on channel 1 which is the default.

Comments • **Output Format:** Typical strings returned have the following function, range, and resolution format:

FREQ, 1.1234567890E+06, 1.0000000000E+01

indicates the channel is configured for frequency, 1.1234567890 MHz range, and 10 Hz resolution.

FREQ AUTO, DEF

indicates the channel is configured for frequency, AUTO range, and DEFault resolution (5 digits of resolution).

Example Query Channel 2 Configuration

CONF2:FREQ 1E5, 10

Channel 2 configured for frequency of 100 kHz with 10 Hz resolution.

CONF2?

Query configuration of channel 2.

enter data

Enter configuration into the computer.

DISPlay

The **DISPlay** command subsystem monitors the state of the selected counter channel. This command is useful only with mainframes that have a front panel display, such as the HP 75000 Series B Mainframe (HP Model Number E1301).

Subsystem Syntax

```
DISPlay
:MONitor
:CHANnel [1|2|3|AUTO]
:CHANnel?
[:STATe] <mode>
[:STATe]?
```

:MONitor:CHANnel

DISPlay:MONitor:CHANnel [1|2|3|AUTO] selects the counter channel to be monitored or AUTO tracking. Use the **DISPlay:MONitor:STATe** command to enable and disable the monitor mode.

Comments

- Specify only one counter channel to monitored. Specify AUTO for channel tracking (displays activity from the last active channel). If a channel number or AUTO is not specified, then AUTO is used.
- Use the AUTO parameter to display measurements from the most recent channel to receive a **CONFigure** or **MEASure** command. The channel number and measurement are updated.
- The following example shows the counter's monitor mode display on the HP E1301A front panel.

```
COUNTER_48:  Chan 1      +1.4653026789E+06
mon  err  freq  mrng      trig:imm
```

Example shows channel 1 measurement returned with 1.4653026789 MHz, monitor on, error detected, frequency function in manual range, trigger source set to immediate.

- ***RST Condition:** DISP:MON:CHAN AUTO

Example Monitoring a Channel

```
DISP:MON:CHAN 1           Select channel 1 for monitor mode.
DISP:MON:STAT ON         Enable monitor mode.
```

:MONitor:CHANnel?

DISPlay:MONitor:CHANnel? returns one of the following numbers to the output buffer indicating the channel being monitored:

```
-1 = AUTO (channel tracking)
 1 = channel 1
 2 = channel 2
 3 = channel 3
```

Example Querying the Monitor Mode Channel

```
DISP:MON:CHAN AUTO       Select channel tracking for monitor.
DISP:MON:STAT ON         Enable monitor mode.
```

DISP:MON:CHAN?

Returns -1 indicating AUTO.

:MONitor[:STATe]

DISPlay:MONitor[:STATe] <mode> turns the monitor mode on or off.

Parameters

Parameter Name	Parameter Type	Range of Values	Default Value
mode	Boolean	OFF (0) ON (1)	OFF

Comments

- **Enabling the Monitor Function:** The [:STATe] parameter is optional. Therefore, either of the following command statements is valid and enable the monitor function:

DISP:MON:STAT ON or DISP:MON ON

- **Selecting the Channel to be Monitored:** Use the DISP:MON:CHAN command to select the channel to be monitored.
- **Disabling Monitor Mode:** Pressing any front panel key while in monitor mode will automatically disable the monitor function.
- ***RST Condition:** DISP:MON:STAT OFF

Example Turning Monitor Mode ON

DISP:MON:CHAN 1 *Monitor channel 1.*
DISP:MON:STAT ON *Enable monitor mode.*

:MONitor[:STATe]?

DISPlay:MONitor[:STATe]? returns a number indicating whether the monitor mode is enabled or disabled: "1" = ON, "0" = OFF. The value is sent to the output buffer.

Comments

- This command is valid only when executed from your computer over the interface bus. The monitor mode is automatically disabled if executed from the mainframe's front panel.
- The [:STATe]? parameter is optional. Therefore, either of the following command statements is valid:

DISP:MON:STAT? or DISP:MON?

Example Querying the Monitor Mode

DISP:MON:CHAN 1 *Select channel 1 for monitor mode.*
DISP:MON:STAT ON *Enable monitor mode.*
DISP:MON:STAT? *Query monitor mode.*
enter statement *Enter value into computer.*

FETCh?

The **FETCh?** command retrieves measurements stored in mainframe/command module memory by the most recent **INITiate** command and places them in the output buffer. This command is most commonly used in conjunction with **CONFigure**.

Subsystem Syntax FETCh[1|2|3]?

Comments

- **Channel Number:** Select only one channel at a time.
- **FETCh? and INITiate:** Execute **INITiate** before sending the **FETCh?** command to place the counter in the wait-for-trigger state. If the counter is in the trigger idle state (that is, the **INITiate** command has not been executed), **FETCh?** will generate the "Data corrupt or stale" error.

- Previous data stored in the output buffer is lost when a **FETCh?** is executed. Typical string returned is as follows:

±1.2345678901E±123

- **TOTalize Measurements:** If the selected channel is configured for totalize, **FETCh?** reads the current value from the Counter and returns the result.

Example Transferring a Measurement to Output Buffer

CONF:RAT	<i>Function is RATio.</i>
INIT	<i>Store readings in mainframe memory; trigger source is IMMEDIATE by default.</i>
FETCh?	<i>Place readings in output buffer.</i>
enter statement	<i>Enter measurement into computer.</i>

INITiate

The **INITiate** command initiates a measurement by controlling a channel's measurement state. Executing an **INITiate** command changes the channel state from the "idle" state to the "wait-for-trigger" state. This command is most commonly used in conjunction with **CONFigure**.

Subsystem Syntax

INITiate[1|2|3]

Comments

- **Channel Number:** Select only one channel at a time.
- **Performing the Measurement:** After the trigger system is initiated using **INIT**, the state of the **TRIGger** command subsystem controls when the actual measurement occurs. (See the **TRIGger** subsystem later in this chapter for more information.)

If **TRIGger:SOURce** is **IMMediate** (the default for **TRIG:SOUR**), the measurement is performed as soon as **INITiate** is executed. The measurement result is stored in mainframe/command module memory. A measurement stored in memory from a previous command is replaced by the new measurement data.

- **Measurement Result:** To transfer a measurement result from mainframe/command module memory to the output buffer, use the **FETCh?** command.
- ***RST Condition:** Places the trigger system in the idle state.

Example Initiating the Trigger System (Wait-For-Trigger State)

CONF:FREQ	<i>Function is frequency.</i>
TRIG:SOUR BUS	<i>Trigger source is bus.</i>
INIT	<i>Place counter in wait-for-trigger state; store measurement in mainframe/command module memory.</i>
FETCh?	<i>Transfer measurement to output buffer.</i>
.	
.	
INIT	<i>Must re-initiate trigger system after each trigger cycle.</i>

INPut

The **INPut** subsystem commands control the input signal conditioning parameters for channels 1 and 2. Parameters controlled by INPut are impedance, attenuation, coupling, and enabling a low-pass filter.

Subsystem Syntax

```
INPut[1|2]
:ATTenuation <value | MIN | MAX | DEF>
:ATTenuation?
:COUPling <mode>
:COUPling?
:FILTer
  [:LPASs]
  [:STATe] <mode>
  [:STATe]?
:IMPedance <value | MIN | MAX | DEF>
:IMPedance?
```

Channel Numbers

Input conditioning affects both channels at the same time. Therefore, it is unnecessary to specify a channel number.

:ATTenuation

INPut:ATTenuation <value | MIN | MAX | DEF> sets the input attenuation to 20 dB or 0 dB.

Parameters

Parameter Name	Parameter Type	Range of Values	Default Units
<i>value</i>	Numeric	-1 to +1 and 19 to 21 dB	dB
MIN	Discrete	0 dB	dB
MAX	Discrete	20 dB	dB
DEF	Discrete	0 dB	dB

Comments

- **Interaction of Channels 1 and 2:** Input attenuation cannot be programmed independently for channels 1 and 2. Specifying 20 dB for channel 2 sets the channel 1 attenuation to 20 dB and vice versa (see the following example).
- Numeric attenuation values are accepted between -1 and +1 for 0 dB and 19 to 21 for 20 dB.
- **Turn-on and *RST Condition:** INP:ATT 0

Example Set Channel 2 Attenuation to 20 dB

```
INP2:ATT MAX
```

Sets channel 2 attenuation to 20 dB (also sets channel 1 attenuation to 20 dB).

:ATTenuation? **INPut:ATTenuation?** returns the attenuation for channels 1 and 2.

Example Query Channel 2 Attenuation

INP2:ATT? *Queries attenuation for channel 2.*

:COUPling **INPut:COUPling <mode>** sets the input coupling to AC or DC.

Parameters

Parameter Name	Parameter Type	Range of Values	Default Value
<i>mode</i>	Discrete	AC DC	AC

Comments

- **Interaction of Channels 1 and 2:** Input coupling cannot be programmed independently for channels 1 and 2. Specifying DC for one channel sets the other channel's coupling to DC.
- **Turn-on and *RST Condition:** INP:COUP AC

Example Set Channel 2 Coupling to DC

INP2:COUP DC *Sets channel 2 coupling to DC; also sets channel 1 coupling to DC.*

:COUPling? **INPut:COUPling?** returns the coupling for channels 1 and 2.

Example Query Channel 2 Coupling

INP2:COUP? *Queries Channel 2 coupling (channel 1 is the same).*

**:FILTer[:LPASs]
[:STATe]** **INPut:FILTer[:LPASs][:STATe] <mode>** enables or disables input low-pass filter.

Parameters

Parameter Name	Parameter Type	Range of Values	Default Value
<i>mode</i>	Boolean	OFF (0) ON (1)	OFF

Comments

- **3 dB Filter Frequency:** The 3 dB filter frequency is 100 kHz.
- **Interaction of Channels 1 and 2:** The input low-pass filter cannot be programmed independently for channels 1 and 2. Specifying ON for either channel enables the other channel filter.

Example Set Channel 2 Filter ON

INP2:FILT:LPAS:STAT ON *Enables the channel 2 low-pass filter (also enables the channel 1 low-pass filter).*

:FILTer[:LPASs] [:STATe]? **INPut:FILTer[:LPASs][:STATe]?** returns the *mode* of the input low-pass filter; OFF (0) or ON (1).

Example Query Channel 2 Filter State

INP2:FILT:LPAS:STAT?

Queries the state of channel 2 low-pass filter (channel 1 low-pass filter is the same state).

:IMPedance **INPut:IMPedance <value | MIN | MAX | DEF>** sets the input impedance to 50Ω or 1 MΩ.

Parameters

Parameter Name	Parameter Type	Range of Values	Default Units
<i>value</i>	Numeric	40 to 60 and .9E6 to 1.1E6	Ohms
MIN	Discrete	50Ω	Ohms
MAX	Discrete	1 MΩ	Ohms
DEF	Discrete	1 MΩ	Ohms

Comments

- **Interaction of Channels 1 and 2:** Input impedance cannot be programmed independently for channels 1 and 2. Specifying 50Ω for channel 2 sets the channel 1 impedance to 50Ω also (see the following example).
- Impedance values can be specified between 40 and 60 for 50 Ω and 0.9E6 to 1.1E6 for 1 MΩ.

Example Set Channel 2 Impedance to 50 Ω

INP2:IMP MIN

Sets channel 2 impedance to 50 Ω (also set channel 1 to 50 Ω).

:IMPedance? **INPut:IMPedance?** returns the impedance channels 1 and 2 are set for.

Example Query Channel 2 Input Impedance

INP2:IMPedance?

Queries the input impedance of channel 2 (channel 1 impedance is the same).

MEASure

The **MEASure** command subsystem sets up the counter to perform a specified measurement either in AUTO range or a manually entered range and then performs the measurement. After making the measurement, the data is stored in mainframe memory and the output buffer.

Subsystem Syntax

```
MEASure[1|2|3]
:FREQuency? [<range>[,<resolution>]]
:NWIDth? [<range>[,<resolution>]]
:PERiod? [<range>[,<resolution>]]
:PWIDth? [<range>[,<resolution>]]
:RATio? [<range>[,<resolution>]]
:TINTerval? [<range>[,<resolution>]]
```

Comments

- **Not TOTalize:** The MEASure command cannot be used to totalize counts because totalize continues counting events until the function is changed.
- **Specifying Range and Resolution:** If the optional parameters are to be used, *range* must be specified if a value for *resolution* is entered. You cannot enter a value for *resolution* without a preceding *range* value.
- **Manual Range:** If the optional parameters *range* and *resolution* are specified, the Counter makes the measurement using the values entered. A slightly faster measurement is made when range is specified since a sample measurement to determine the correct range is unnecessary.
- **Auto Range:** If the optional parameters *range* and *resolution* are not entered, the input signal is sampled to determine the proper *range* setting. *Resolution* is set for a default *resolution* of 5 digits (4 digits for RATio).
- **MEASure versus CONFigure and SENSE:** Most measurements can be performed using one of these three subsystems, and each has advantages and disadvantages over the other. The differences in the commands are:

The CONFigure command can be used for all measurements. The CONFigure command only configures a channel for a specific function, and does not perform the measurement. Use of additional commands (READ? or INIT/FETC?) to perform the measurement and read the results is necessary. The choice of manual or AUTO ranging for frequency and period functions is provided through the use of optional parameters.

The MEASure command can be used for all measurements except TOTalize. The MEASure command configures a channel for a specific function, performs the measurement, and returns the result to the output buffer. The choice of manual or AUTO ranging for frequency and period functions is provided through the use of optional parameters.

Both CONFIGure and MEASure commands are instrument independent and can be used in other instruments to perform similar functions. Use these commands when the portability of instrument syntax is important.

The SENSE subsystem can be used for all measurements. The SENSE:FUNCTION command only configures a channel for a specific function and does not perform the measurement. Use of additional commands (READ? or INIT/FETC?) to perform the measurement and store the results is necessary. Only manual ranging for frequency and period functions is provided, and these parameters may be entered using an additional command (SENS:FREQ:APER or SENS:PER:NPER).

The SENSE commands are instrument dependent and may behave differently in other instruments. These commands should be used when direct control over the measurement is important.

- **Output Format:** After the measurement is complete, the results are sent to the output buffer. Previous data in the output buffer is lost when the MEAS command is executed. Typical string returned is as follows:

1.234567801E+006

:FREQuency? MEASure[1|2|3]:FREQuency? [<range>[,<resolution>]] configures the Counter for the frequency measurement function, performs the measurement, and transfers the measurement to the output buffer.

Parameters

Parameter Name	Parameter Type	Range of Values	Default Value
<i>range</i>	Numeric or Discrete	29.1E-3 to 100E6 Hz (ch 1 & 2) 75E6 to 1E9 Hz (ch 3) MIN MAX AUTO	AUTO
<i>resolution</i>	Numeric or Discrete	4.2E-15 to 500 Hz MIN MAX	5 digits

Comments

- **Type of Signal Measured:** Signals must be periodic for the frequency function.
- **Entering Range:** *Range* can be entered as a number in Hz from 0.002 Hz to 100 MHz for channels 1 and 2. For channel 3, *range* can be entered as a number in Hz from 75 MHz to 1 GHz. AUTO range is selected when *range* is not specified. Refer to the section titled “Selecting Range and Resolution” on page 46 for more information.
- **Entering Resolution:** *Resolution* is entered as a number from 4.2E-15 Hz to 500 Hz. Entries up to 1E8 for channels 1 and 2 and 1E9 for channel 3 will be accepted. *Resolution* is automatically set for 5 digits of resolution (4 digits for RATio function) by not entering a value for the optional *resolution* parameter. If *resolution* is

entered, *range* must also be entered. Refer to the section titled “Selecting Range and Resolution” on page 46 for more information.

- **Overflow Indication:** Overflow is detected by querying the Questionable Data/Signal Register (see the STATus subsystem later in this chapter).

Example Making Frequency Measurements

MEAS:FREQ? 1E6,10

Channel 1; function is FREQuency; range is 1 MHz; resolution is 10 Hz.

:NWIDth? **MEASure[1|2]:NWIDth? [<range>,<resolution>]** configures the Counter for the negative pulse width measurement function on channel 1 or 2, makes the measurement, and transfers the measurement to the output buffer.

Parameters **Entering Range:** Measurement *range* is from 200 nsec to 6871 seconds.

Entering Resolution: *Resolution* can be entered as a number in seconds from 0.781 nsec to 100 nsec. Entries up to 6871 seconds will be accepted. *Resolution* is automatically set to 5 digits by not entering values for *range* and *resolution*. If *resolution* is entered, *range* must also be entered. Refer to the section titled “Selecting Range and Resolution” on page 46 for more information.

Comments

- **Channel Selection:** Select only one channel at a time. Channel 3 cannot make pulse width measurements.
- **Edge Select:** Negative pulse width is measured from the falling edge to the rising edge. The command will hang until the second edge is detected. If none is detected within 6871 seconds, an overflow occurs (see next item).
- **Overflow Indication:** Overflow is detected by reading the Questionable Data/Signal Register (see the STATus subsystem later in this chapter).

Example Making Negative Pulse Width Measurements

MEAS:NWID?

Channel 1; function is negative pulse width.

:PERiod? **MEASure[1|2]:PERiod? [<range>[,<resolution>]]** configures the Counter for the period average measurement function on channel 1 or 2, performs the measurement, and transfers the measurement to the output buffer.

Parameters

Parameter Name	Parameter Type	Range of Values	Default Value
<i>range</i>	Numeric	10E-9 to 6871 MIN MAX AUTO	AUTO
<i>resolution</i>	Numeric	1.5E-18 to .002 sec MIN MAX DEF	5 digits

Comments

- **Channel Selection:** Select only one channel at a time. Channel 3 cannot make period measurements.
- **Type of Signal Measured:** Signals must be periodic for the period function.
- **Entering Range:** *Range* is entered as a number in seconds from 10 nsec to 6871 seconds. The counter uses AUTO range when the *range* parameter is not specified. Refer to the section titled “Selecting Range and Resolution” on page 46 for more information.
- **Entering Resolution:** *Resolution* is entered as a number in seconds from 1.5E-18 to .002 seconds. Entries up to 6871 seconds will be accepted. *Resolution* is automatically set to 5 digits if *range* and *resolution* are not specified in the command. If *resolution* is entered, it must be preceded by a *range* value. Refer to the section titled “Selecting Range and Resolution” on page 46 for more information.
- **Overflow Indication:** Overflow can be detected by reading the Questionable Data/Signal Register (see the STATus subsystem later in this chapter).

Example Making Period Measurements

MEAS:PER? 1E-3,1E-6

*Function is period;
range is 1 mS;
resolution is 1 μS.*

enter statement

Enter readings into computer.

:PWIDth? **MEASure[1|2]:PWIDth? [<range>[,<resolution>]]** configures the Counter for the positive pulse width measurement function on channel 1 or 2, makes the measurement, and transfers the measurement to the output buffer.

Parameters **Entering Range:** Measurement *range* is from 200 nsec to 6871 seconds.

Entering Resolution: *Resolution* can be entered as a number in seconds from 0.781 nsec to 100 nsec. Entries up to 6871 seconds will be accepted. *Resolution* is automatically set to 5 digits by not entering values for *range* and *resolution*. If *resolution* is entered, *range* must also be entered. Refer to the section titled “Selecting Range and Resolution” on page 46 for more information.

Comments

- **Channel Selection:** Select only one channel at a time. Channel 3 cannot make pulse width measurements.
- **Edge Select:** Positive pulse width is measured from the rising edge to the falling edge. The command will hang until the second edge is detected. If none is detected within 6871 seconds, an overflow occurs (see next item).
- **Overflow Indication:** Overflow is detected by reading the Questionable Data/Signal Register (see the STATus subsystem later in this chapter).

Example **Making Positive Pulse Width Measurements**

MEAS:PWID?

Channel 1; function is positive pulse width.

:RATio? **MEASure[1|2]:RATio? [<range>,<resolution>]** configures the Counter for the ratio measurement function, makes the measurement, and transfers the measurement to the output buffer. A ratio measurement requires both channels 1 and 2 with the specified channel as the numerator of the ratio.

Parameters

Parameter Name	Parameter Type	Range of Values	Default Value
<i>range</i>	Numeric	9.3E-10 to 1E9	AUTO
<i>resolution</i>	Numeric	1.35E-20 to .0156 (1/64)	4 digits

Comments

- **Type of Signals Measured:** Signals must be periodic for the ratio function.
- **Specifying the Channel:** Select only one channel at a time. The channel declared in the command is in the numerator of the ratio. For example, if channel 2 is specified (MEAS2:RAT?), the result will be the ratio of channel 2/channel 1.
- **Entering Range:** *Range* is entered as a number from 9.3E-10 to 1E9. The counter uses AUTO range when the *range* parameter is not specified. Refer to the section titled “Selecting Range and Resolution” on page 46 for more information.
- **Entering Resolution:** *Resolution* is entered as a number from 1.35E-20 to 0.0156. 4 digits of resolution is automatically set if *resolution* is not specified in the command. Refer to the section titled “Selecting Range and Resolution” on page 46 for more information.
- **Overflow Indication:** Overflow is detected by reading the Questionable Data/Signal Register (see the STATus subsystem later in this chapter).

Example Making Ratio Measurements (ratio of Channel 1 over Channel 2)

MEAS:RAT? *Function is RATio (ch1/ch2).*
 enter statement *Enter readings into computer.*

:TINTerval?

MEASure[1|2]:TINTerval? [<range>[,<resolution>]] configures the Counter for the time interval measurement function on channel 1 or 2, makes the measurement, and transfers the measurement to the output buffer.

Parameters

This command ignores the *range* parameter but will accept the *resolution* parameter if a numeric *range* parameter precedes it. You must send a value for the *range* parameter for *resolution* to be accepted even though it is ignored.

Parameter Name	Parameter Type	Range of Values	Default Value
<i>range</i>	Numeric	200E-9 to 6871	
<i>resolution</i>	Numeric	1E-7 to 1E-7/128 (7.81E-10)	100 nsec

Comments

- **Channel Selection:** Select only one channel at a time. Channel 3 cannot make time interval measurements.
- **Specifying the Channel:** The channel declared in the command is the channel the time interval measurement begins with. For example, if channel 2 is specified (MEAS2:TINT?), the result will be the time interval from the event at channel 2 to the event at channel 1.
- **Start and Stop Edges:** The edges of both the start and stop channels can be selected using the SENSE:SLOPe command. Unless changed, the measurement will be performed using the presently selected slope.
- **Entering Range:** The *range* parameter is ignored for time interval measurements but must be entered if the *resolution* parameter is entered. Any numeric value for *range* will work.
- **Entering Resolution:** *Resolution* is entered as a number from 1E-7 to 1E-7/128. 100 nsec default resolution is used if a *resolution* is not specified in the command. Refer to the section titled “Selecting Range and Resolution” on page 46 for more information.
- **Overflow Indication:** Overflow is detected by reading the Questionable Data/Signal Register (see the STATus subsystem later in this chapter).

Example Making Time Interval Measurements (Channel 1 to Channel 2)

MEAS:TINT?

Function is TINT.

enter statement

Enter readings into computer.

READ?

The **READ?** command is used to initiate a measurement and then transfer the measurement result to the output buffer. The **READ?** command performs the identical function as an **INITiate** and **FETCh?** command.

Subsystem Syntax

READ[1|2|3]?

Comments

- **Channel Selection:** Specify only one channel at a time. If a channel is not specified, the command defaults to channel 1.
- **Not with TOTAlize:** The **READ?** command cannot be used with the **TOTAlize** function since totalize is an event counter and does not stop counting until the channel is configured for another function. See the **INIT** and **FETC?** commands for reading results of these functions.

- **Output Format:** A typical string returned is as follows:

±1.2345678901E±123

Each measurement is terminated with a Line Feed (LF). The HP-IB End-or-Identify (EOI) signal is sent with the last byte.

- ***RST Condition:** Places the trigger system in the idle state.

Example Transferring Readings Directly to Output Buffer

CONF:RAT

Function is RATio.

READ?

Take measurement; transfer data to output buffer; trigger source is IMMEDIATE by default.

enter statement

Enter readings into computer.

[SENSe:]

The **[SENSe:]** command subsystem can be used to manually configure all available measurements, and/or enter various measurement parameters. The **[SENSe:]** command offers direct manual control of measurement functions and parameters.

When using the **[SENSe:]** subsystem to configure frequency or period measurements, the aperture time and number of periods can be verified and/or changed. Additionally, event slope and event level for all measurements using **CONFigure**, **MEASure**, or **SENSe** can be verified and/or changed using the **[SENSe:]** subsystem.

SENSe enables you to change the following settings:

- Trigger Level
- Trigger Slope
- Function
- Aperture Time
- Number of Periods

Subsystem Syntax

```
[SENSe[1|2|3]:]
EVENT
:LEVel <number | MIN | MAX | DEF>
:LEVel?
:SLOPe <POS | NEG>
:SLOPe?
FREQuency
:APERture <number | MIN | MAX | DEF>
:APERture?
FUNction
:FREQuency
:NWIDth
:PERiod
:PWIDth
:RATio
:TINTerval
:TOTalize
FUNction?
PERiod
:NPERiods <number | MIN | MAX | DEF>
:NPERiods?
RATio
:NPERiods <number | MIN | MAX | DEF>
:NPERiods?
TINTerval
:NPERiods <number | MIN | MAX | DEF>
:NPERiods?
```

EVENT:LEVel [SENSe[1|2]:]EVENT:LEVel <*number* | MIN | MAX | DEF> specifies the trigger level for channels 1 and 2.

Parameters

Parameter Name	Parameter Type	Range of Values	Default Value
<i>number</i>	Numeric	-2.56V to +2.54V MIN MAX DEF	0 V
MIN	Character	-2.56V	
MAX	Character	+2.54V	
DEF	Character	0V	

Comments

- Event level is programmable in 20 mV steps on channels 1 and 2. Each channel can have a different trigger level programmed. Values entered outside the range will generate an error.
- When attenuation is 0 dB, entered levels of -2.56 to +2.54V in 20 mV steps behave as entered.
- When the attenuation is programmed for 20 dB, levels are entered as -2.56 to +2.54V in 20 mV steps, but behave as -25.6 to +25.4V in 200 mV steps.
- The event level is 0V at turn-on or reset.

Example Set Channel 2 Trigger Level to +1.2V

SENS2:EVEN:LEV 1.2 *Sets channel 2 level to +1.2V.*

EVENT:LEVel? [SENSe[1|2]:]EVENT:LEVel? returns one of the following responses to the output buffer:

- The current trigger level if no parameter is specified.
- The minimum trigger level available if MIN is specified.
- The maximum trigger level available if MAX is specified.
- The default trigger level if DEF is specified.

Example Querying the Trigger Level Setting of Channel 2

SENS2:EVEN:LEV? *Query trigger level of Channel 2.*
 enter statement *Enter value into computer.*

EVENT:SLOPe [SENSe[1|2]:]EVENT:SLOPe <POSitive | NEGative> specifies either the POSitive (rising) or NEGative (falling) edge of the input signal as the sense event slope for the measurement. This setting is used only for time interval measurements (TINTerval). Time interval measurements require both channels 1 and 2; one channel providing the start edge while the other provides the stop edge for the measurement. The SLOPe command defines the edges.

- Comments**
- The slope setting on channels 1 and 2 are used for time interval measurements only. Each channel's slope can be independently programmed.
 - At turn-on or reset the slope is positive.

Example Set Channel 2 Trigger Slope to Negative

SENS2:EVENT:SLOP NEG *Sets channel 2 slope negative.*

EVENT:SLOPe? [SENSe[1|2]:]EVENT:SLOPe? returns one of the following responses:

- POS if slope is set positive.
- NEG if slope is set negative.

Example Querying the Slope Setting of Channel 2

SENS2:EVENT:SLOP? *Query slope of Channel 2.*
 enter statement *Enter value into computer.*

FREQuency :APERture [SENSe[1|2]:]FREQuency:APERture <number | MIN | MAX | DEF> specifies the aperture time for a frequency measurement. Table 4-2 in Chapter 4 shows the sixteen resolution choices you have for frequency, the corresponding aperture time, and the maximum frequency for 6-digit and 5-digit resolution. The resolution choices are limited to the sixteen steps of aperture time using the direct frequency measurement technique. Table 4-3 shows the sixteen resolution choices you have for frequency measurements using the period averaging technique.

Parameters

Parameter Name	Parameter Type	Range of Values	Default Value
<i>number</i>	Numeric	2 mS to 65.536 S	2 mS
MIN	Character	2 mS	
MAX	Character	65.536 S	
DEF	Character	2 mS	

- Comments**
- **Channel Selection:** Select only one channel at a time.

- **Aperture Time versus Resolution:** Aperture time is the gate time in which frequency measurements are made using the SENSE:FUNCTION command. A larger aperture time is required to obtain greater resolution. Refer to the section titled “Selecting Aperture Time and Number of Periods” on page 47 for more information.
- **Selecting Aperture Time:** Aperture time is programmable in 16 binary steps from 2 mS to 65.536 Seconds (MIN to MAX i.e., 2, 4, 8, 16, 32, 64 mS, etc.). If an aperture time is specified that is not an exact step, the next highest step is used. Selecting DEF or MIN enter 2E-3 seconds; MAX enters 65.536 seconds. Specifying a value out of range will generate an error.
- ***RST Condition:** SENS:FREQ:APER 2E-3

Example Set Channel 1 Frequency Aperture Time to 128 mS

SENS:FREQ:APER 128E-3	<i>Sets channel 1 (default) frequency aperture to 128 mS.</i>
FREQ:APER 128E-3	<i>Specifies aperture time same as previous statement.</i>

FREQUENCY:APERture?

[SENSe:]FREQUENCY:APERture? [MIN | MAX | DEF] returns one of the following numbers to the output buffer:

- The current aperture time in seconds if no parameter is specified.
- The minimum aperture time available if MIN is specified.
- The maximum aperture time available if MAX is specified.
- The default aperture time if DEF is specified.

Comments

- **Output Format:** The query will return a result in seconds from 2 msec to 65.536 seconds. Typical string returned is as follows:

8.19200000E+000

Example Querying the Aperture Time

SENS:FREQ:APER 256E-03	<i>Aperture time is 256 mS.</i>
FREQ:APER?	<i>Query counter aperture time.</i>
enter statement	<i>Enter value into computer.</i>

FUNCTION You specify the measurement function with the following command:

[SENSe[1|2|3]:]FUNctioN:<*function*>

This command is used to set up the Counter to perform a specified measurement in manual range but does not perform the actual measurement. Depending on measurement function selected, additional SENSe commands may need to be executed.

Parameters

Parameter Name	Parameter Type	Range of Values	Default Value
<i>function</i>	Discrete	FREQuency PERiod RATio TINterval PWIDth NWIDTH TOTalize	FREQ

Comments

- **Channel Number:** Select only one channel at a time.
- **Selecting the Sensor Function:** Depending on the sensor function selected, additional SENSe commands may need to be executed before proceeding with the measurement.
 - If function is FREQuency, use the SENSe:FREQuency:APERture command to enter aperture time.
 - If function is PERiod, use the SENSe:PERiod:NPERiod command to enter number of periods.
- **Measurement Description:** See the CONFigure subsystem earlier in this chapter for a description of all available measurements.
- **SENSe versus MEASure and CONFigure:** Most measurements can be performed using one of these three subsystems, and each has advantages and disadvantages over the other. The differences in the commands are:

The CONFigure command can be used for all measurements. The CONFigure command only configures a channel for a specific function, and does not perform the measurement. Use of additional commands (READ? or INIT/FETC?) to perform the measurement and read the results is necessary. The choice of manual or AUTO ranging for frequency and period functions is provided through the use of optional parameters.

The MEASure command can be used for all measurements except TOTalize. The MEASure command configures a channel for a specific function, performs the measurement, and returns the result to the output buffer. The choice of manual or AUTO ranging for frequency and period functions is provided through the use of optional parameters.

Both CONFIGure and MEASure commands are instrument independent and can be used in other instruments to perform similar functions. Use these commands when the portability of instrument syntax is important.

The SENSE subsystem can be used for all measurements. The SENSE:FUNCTION command only configures a channel for a specific function and does not perform the measurement. Use of additional commands (READ? or INIT/FETC?) to perform the measurement and store the results is necessary. Only manual ranging for frequency and period functions is provided, and these parameters may be entered using an additional command (SENS:FREQ:APER or SENS:PER:NPER).

The SENSE commands are instrument dependent and may behave differently in other instruments. These commands should be used when direct control over the measurement is important.

Example Set Channel 1 Function to Positive Pulse Width

(NOTE: Both examples do the same thing).

SENS:FUNC:PWID	<i>Sets channel 1 (default) function to positive pulse width.</i>
FUNC:PWID	<i>Abbreviated command for setting function.</i>

FUNCTION? [SENSe[1|2|3]:]FUNCTION? returns one of the following functions listed in the SENSE:FUNCTION command section: FREQ, PER, RAT, TINT, PWID, NWID, or TOT.

Comments

- **Channel Selection:** Select only one channel at a time.

Example Querying the Measurement Function

FUNC:RAT	<i>Function is RATio.</i>
FUNC?	<i>Query selected function.</i>
enter statement	<i>Enter string into computer.</i>

PERiod:NPERiods

[SENSe[1|2]:]PERiod:NPERiods <*number* | MIN | MAX | DEF> is used to enter the number of periods for a period average measurement configured using the SENSe:FUNcTion command. All period measurements are made by averaging from 2 to 65536 periods.

Parameters

Parameter Name	Parameter Type	Range of Values	Default Value
<i>number</i>	Numeric	2 to 65536 periods	2
MIN	Character	2 periods	
MAX	Character	65536 periods	
DEF	Character	2 periods	

Comments

- **Channel Selection:** Select only one channel at a time.
- **Selecting Number of Periods to Average:** Number of periods is programmable in 16 binary steps from 2 to 65536 (MIN to MAX i.e., 2, 4, 8, 16, 32, 64, etc.). If a value is specified that is not an exact step, the next highest binary value is selected. Selecting DEF or MIN enters 2 cycles, and MAX enters 65536 cycles. Selecting a value out of range will generate an error.
- **Number of Periods versus Resolution:** Number of Periods is the number of periods that are measured and averaged for period measurements made using the SENSe:FUNcTion command. A larger number of periods is required to obtain greater resolution. Refer to the section titled “Selecting Aperture Time and Number of Periods” on page 47 for more information.
- **Maximum Time Allowed:** The maximum time allowed for N periods is 6871 seconds. If this is exceeded, the associated channel bit in the Questionable Data Register is set.

Example Set Channel 1 Number of Periods to 256

PER:NPERS 256

Sets channel 1 (default) number of periods to 256.

PER:NPERS 175

Also will set number of periods to 256.

PERiod:NPERiods?

[SENSe[1|2]:]PERiod:NPERiods? [MIN | MAX | DEF] returns one of the following numbers to the output buffer:

- The current number of periods if no parameter is specified.
- The minimum number of periods available if MIN is specified.
- The maximum number of periods available if MAX is specified.
- The default number of periods if DEF is specified.

Comments

- **Output Format:** The query will return the number of periods from 2 to 65536 periods. Typical string returned is as follows:

8.1920000E+003

Example Querying the Number of Periods

SENS:PER:NPERS 16

Number of periods is 16.

SENS:PER:NPERS?

Query counter to return the number of periods.

enter statement

Enter value into computer.

RATio:NPERiods

[SENSe[1|2]:]RATio:NPERiods <number | MIN | MAX | DEF> specifies the number of periods averaged for a ratio measurement. All ratio measurements are made by ratio averaging from 64 (2^6) to $6.8719E+10$ (2^{36}) periods.

Parameters

Parameter Name	Parameter Type	Range of Values	Default Value
<i>number</i>	Numeric	64 to $6.8719E+10$ periods	64
MIN	Character	64 periods	
MAX	Character	$6.8719E+10$ periods	
DEF	Character	64 periods	

Comments

- **Values of Number of Periods:** Number of periods is programmed in 31 binary steps from 64 to $6.8719(10E10)$ (MIN to MAX). If a number is specified that is not an exact step, the next highest step is selected. A value specified out of range will generate an error.

Example Set Channel 1 Number of Periods to 512 for a Ratio Measurement

SENS:RAT:NPERS 512

Sets channel 1 (default) number of periods to 512.

RATio:NPERiods?

[SENSe[1|2]:]RATio:NPERiods? [MIN | MAX | DEF] returns one of the following numbers:

- The current number of periods if no parameter is specified.
- The minimum number of periods available if MIN is specified.
- The maximum number of periods available if MAX is specified.
- The default number of periods if DEF is specified.

Example Querying the Number of Periods

```
SENS:RAT:NPERS 512           Number of periods is 512.
SENS:RAT:NPERS?             Query counter to return the
                              number of periods.
enter statement              Enter value into computer.
```

TINTerval:NPERiods

[SENSe[1|2]:]TINTerval:NPERiods <number | MIN | MAX | DEF> specifies the number of measurements to average for the following measurements:

- time interval (TINT)
- positive pulse width (PWID)
- negative pulse width (NWID)

Measurements for the three functions are made by time interval averaging from 1 to 128 periods.

Parameters

Parameter Name	Parameter Type	Range of Values	Default Value
<i>number</i>	Numeric	1 to 128 periods	1
MIN	Character	1 period	
MAX	Character	128 period	
DEF	Character	1 period	

Comments

- Number of periods can be set from 1 to 128 (MIN to MAX) in 8 binary steps. If a number is specified that is not an exact step, the next highest step is selected.
- The maximum time interval or pulse width that can be measured is 6871 seconds with 100 nS/TINT:NPERS resolution.
- The maximum time allowed for a measurement is the maximum time interval (6871 seconds) times the maximum number of measurements (128). Note that measuring a large time interval for many periods may cause the counter to appear non-functioning.

Example Set Channel 2 Number of Periods to 64 for a Time Interval Measurement

TINT:NPERS 64

Sets channel 2 NPER to 64.

TINTerval:NPERS?

[SENSe[1|2]:]TINTerval:NPERS? [MIN | MAX | DEF] returns one of the following numbers to the output buffer:

- The current number of periods if no parameter is specified.
- The minimum number of periods available if MIN is specified.
- The maximum number of periods available if MAX is specified.
- The default number of periods if DEF is specified.

Example Querying the Number of Periods

SENS:TINT:NPERS 512

Number of periods is 512.

TINT:NPERS?

Query counter to return the number of periods.

enter statement

Enter value into computer.

STATus

The **STATus** subsystem reports measurement overflows by reading the bit value of the Questionable Data/Signal Register. Bits 9, 10, and 11 are used by the HP E1333A 3-Channel Universal Counter.

Subsystem Syntax STATus
 :QUEStionable
 :CONDition?
 :ENABle <number>
 :ENABle?
 [:EVENT]?

The STATus system contains four registers, two of which are under IEEE 488.2 control. These are the Standard Event Status Register (*ESE) and the Status Byte Register (*STB). Refer to the appropriate mainframe or command module operating manual for more information on these registers.

The two registers under the Counter's control are the Standard Operational/Status Register, and the Questionable Data/Signal Register. The Standard/Operational Status Register is not used in the Counter and will not be discussed. The Questionable Data/Signal Register is discussed below. The figure shown below illustrates the STATus system Registers. The various registers are set and queried using decimal weighted bit values. The decimal equivalent for bits 0 to 15 is shown below.

Bit Number to Decimal Value

Bit #	0	1	2	3	4	5	6	7	8	9	10	11	12	13	14	15
Decimal Value	1	2	4	8	16	32	64	128	256	512	1024	2048	4096	8192	16384	32768

Sending a decimal value of 3584 will set bits 9, 10, and 11.

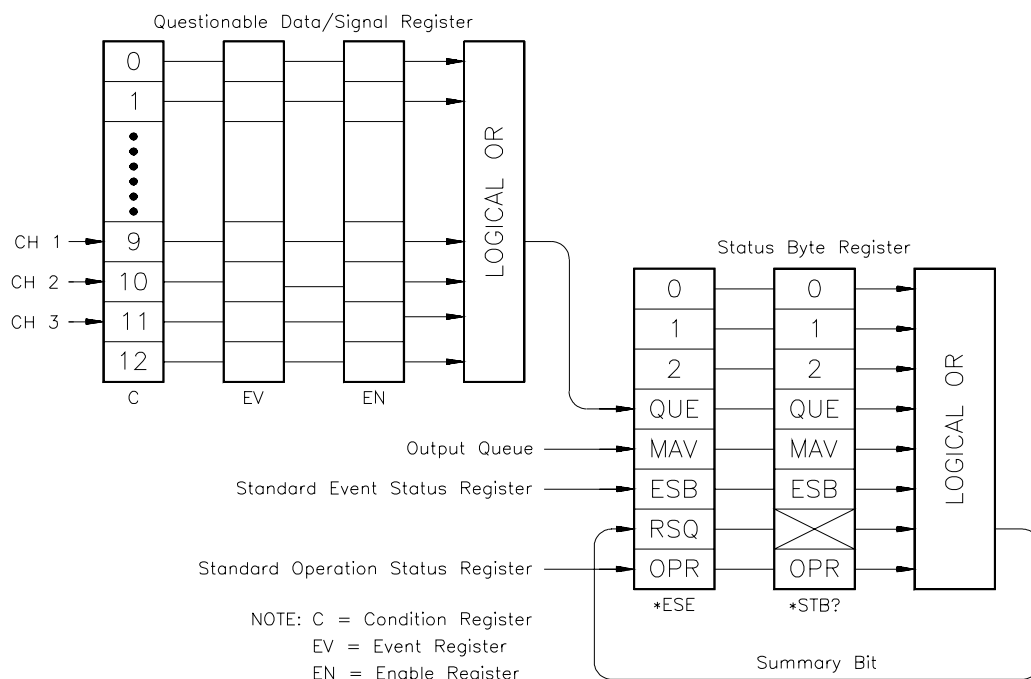

:QUESTIONable **STATUS:QUESTIONable** subsystem commands query the Questionable Register to indicate whether an overflow has occurred on a given channel after an INIT, FETC?, READ?, or MEASure command has executed. Bit 9 of the Questionable Register reports questionable data on channel 1, channel 2 uses bit 10, and channel 3 uses bit 11. When any of the three bits are set to 1 (questionable data), bit 3 of the Status Register is set to 1 if enabled by the STAT:QUES:ENAB command.

:QUESTIONable :CONDition? **STATUS:QUESTIONable:CONDition?** queries the contents of the Questionable Data/Signal Condition Register. The contents of the Condition Register reflect the state of the last measurement on each particular channel.

- Comments**
- **Information Updated:** The Condition Register is updated whenever a measured value is read from the Counter (MEAS?, INIT, READ?, and FETC? commands).
 - **Output Format:** Returns a decimal weighted value from 0 to 3584 indicating which bits are set true.
 - **Reading Contents:** Reading the Condition Register does not destroy its contents.

Example **Read the Questionable Condition Register**

STAT:QUES:COND? *Queries the Questionable Condition Register.*

:QUESTIONable :ENABLE **STATUS:QUESTIONable:ENABLE <number>** sets the enable mask which allows true conditions in the Questionable Data/Signal Event Register to be reported in the summary bit (setting Status Byte Register bit 3 true).

Parameters

Parameter Name	Parameter Type	Range of Values	Default Units
<i>number</i>	Numeric	1 to 32768	none

- Comments**
- **Summary Bit:** If bits 9, 10, or 11 are 1 in the Questionable Data/Signal Enable Register, a transition of Event Register bits 9, 10, or 11 will cause the associated summary bit to be true.
 - **Maximum Value Entered:** The maximum decimal weighted value used in the Counter module is 3584 (bits 9, 10, and 11 set true).

Example **Enable bits 9, 10, and 11 in the Questionable Data Register**

STAT:QUES:ENAB 3584 *Sets bits true.*

**:QUESTIONable
:ENABLE?** **STATus:QUESTIONable:ENABLE?** returns the bit value of the Questionable Data/Signal Enable Register.

Comments

- **Output Format:** The command returns a decimal weighted value from 0 to 65535 indicating which bits are set true.

Example **Query the Questionable Enable Register**

STAT:QUES:ENAB? *Queries the enable register.*
enter data *Enter data into the computer.*

**:QUESTIONable
[:EVENT]?** **STATus:QUESTIONable[:EVENT]?** Queries the status of the Questionable Data/Signal Event Register.

Comments

- **Information Updated:** The Event Register latches only low to high events from the Condition Register.
- **Output Format:** Returns a decimal weighted value from 0 to 3584 indicating which bits are set true.
- **Reading Contents:** Reading the Event Register by a query will clear its contents.

Example **Read the Questionable Event Register**

STAT:QUES:EVENT? *Queries the Questionable Event Register.*
STAT:QUES? *The short version of the command.*

SYSTEM

The **SYSTEM** command subsystem returns error numbers and messages in the error queue.

Subsystem Syntax SYSTEM
 :ERRor?

:ERRor? **SYSTEM:ERRor?** returns the error numbers and corresponding error messages in the error queue. See Appendix C in this manual for a listing of the error numbers and messages.

Comments

- When an error is generated by the counter, it stores an error number and corresponding message in the error queue.
- One error is removed from the error queue each time the **SYSTEM:ERRor?** command is executed. The errors are cleared in a first-in, first-out order. This means that if several errors are waiting in the queue, each **SYSTEM:ERRor?** query will return the oldest (not the most recent) error. That error is then removed from the queue.
- When the error queue is empty, subsequent **SYSTEM:ERRor?** queries returns +0, "No error". To clear all errors from the queue, execute the ***CLS** command.
- The error queue has a maximum capacity of 30 errors. If the queue overflows, the last error is replaced with -350, "Too many errors". No further errors are accepted by the queue until space becomes available.
- ***RST Condition:** **RST does not* clear the error queue.

Example Reading the Error Queue

SYST:ERR?

Query the error queue.

TRIGger

The **TRIGger** command subsystem controls the behavior of the trigger system once it is initiated (see the **INITiate** subsystem earlier in this chapter). The **TRIGger** subsystem can control:

- An immediate software trigger (**TRIGger:IMMEDIATE**).
- The source of the trigger (**TRIGger:SOURce**).

Subsystem Syntax

```
TRIGger  
[:IMMEDIATE]  
:SOURce <source>  
:SOURce?
```

[:IMMEDIATE]

TRIGger[:IMMEDIATE] causes a trigger cycle to occur immediately provided the trigger system is initiated (see the **INITiate** subsystem earlier in this chapter) and the trigger source is either **TRIGger:SOURce BUS** or **TRIGger:SOURce HOLD**.

Comments

- The **[:IMMEDIATE]** parameter is optional; therefore, **TRIGger:IMMEDIATE** and **TRIGger** have the same effect.
- When the **TRIG:IMM** command is executed, the measurement is stored in mainframe/command module memory. Use **FETCh?** to transfer the measurement to the output buffer.
- The **TRIGger:SOURce BUS** or **TRIGger:SOURce HOLD** command remains in effect after the **TRIG:IMM** command is executed.

Example Sending an Immediate Trigger

CONF:FREQ	<i>Function is frequency.</i>
TRIG:SOUR HOLD	<i>Suspend triggering.</i>
INIT	<i>Place counter in wait-for-trigger state.</i>
TRIG	<i>Trigger the counter.</i>
FETC?	<i>Place measurement in the output buffer.</i>

:SOURce

TRIGger:SOURce <source> configures the trigger system to respond to the specified source. The following sources are available:

- **BUS:** Group Execute Trigger (GET) bus command or *TRG common command.
- **HOLD:** Suspend triggering. Only the **TRIGger:IMMEDIATE** command will trigger the counter.
- **IMMEDIATE:** The trigger system is always true (continuous triggering).

Parameters

Parameter Name	Parameter Type	Range of Values	Default Value
<i>source</i>	Discrete	BUS HOLD IMMEDIATE	IMM

Comments

- The TRIGger:SOURce command only selects the trigger source. The INITiate command enables the trigger system and the trigger source. (The MEASure command automatically executes an INITiate command.)
- TRIGger[:IMMEDIATE] causes a trigger cycle to occur immediately provided the trigger system has been initiated (wait-for-trigger state) by the INITiate command. The trigger source must be TRIGger:SOURce BUS or TRIGger:SOURce HOLD to use TRIGger[:IMMEDIATE].
- The CONFigure and MEASure command subsystems automatically set the trigger source to TRIG:SOUR IMM.
- The READ? command cannot be used if the trigger source is TRIG:SOUR BUS or TRIG:SOUR HOLD.
- ***RST Condition:** TRIG:SOUR IMM

Example Setting the Trigger Source

CONF:PER	<i>Function is period.</i>
TRIG:SOUR BUS	<i>Trigger source is the bus.</i>
READ?	<i>Place counter in wait-for-trigger state.</i>
	<i>Measurement is made at the GET bus command or *TRG common command.</i>

:SOURce? TRIGger:SOURce? returns BUS, HOLD, or IMM, indicating the current trigger source. The quoted string is sent to the output buffer.

Example Querying the Trigger Source

TRIG:SOUR HOLD	<i>Trigger source is suspended.</i>
TRIG:SOUR?	<i>Query counter to return trigger source setting.</i>
enter statement	<i>Enter value into computer.</i>

IEEE 488.2 Common Commands

The following table lists the IEEE 488.2 Common (*) Commands that can be executed by the HP E1333A 3-Channel Universal Counter.

Command	Title	Description																		
*IDN?	Identification	Returns the identification string of the counter.																		
*RST	Reset	Resets the counter. Sets FUNC:FREQ, <range> = AUTO, <resolution> = 5 digits, INP:ATT 0, INP:COUP AC, INP:IMP 1 M Ω , INP:FILT OFF, EVEN:LEV 0, EVEN:SLOP POS, FREQ:APER 2E-3, PER:NPER 2, TRIG:SOUR IMM.																		
*TST?	Self-Test	Returns 0 if self-test passes or error 1 - 7 if failed: <table border="0"> <thead> <tr> <th>Response</th> <th>Description</th> </tr> </thead> <tbody> <tr> <td>0</td> <td>Self-test passed.</td> </tr> <tr> <td>1</td> <td>Counter did not power-up properly.</td> </tr> <tr> <td>2</td> <td>Problem with digital portion of trigger level.</td> </tr> <tr> <td>3</td> <td>Counter did not properly measure frequency.</td> </tr> <tr> <td>4</td> <td>Counter did not properly measure period.</td> </tr> <tr> <td>5</td> <td>Counter did not properly totalize.</td> </tr> <tr> <td>6</td> <td>Problem with analog portion of trigger level.</td> </tr> <tr> <td>7</td> <td>Counter is not in proper state after being reset.</td> </tr> </tbody> </table>	Response	Description	0	Self-test passed.	1	Counter did not power-up properly.	2	Problem with digital portion of trigger level.	3	Counter did not properly measure frequency.	4	Counter did not properly measure period.	5	Counter did not properly totalize.	6	Problem with analog portion of trigger level.	7	Counter is not in proper state after being reset.
Response	Description																			
0	Self-test passed.																			
1	Counter did not power-up properly.																			
2	Problem with digital portion of trigger level.																			
3	Counter did not properly measure frequency.																			
4	Counter did not properly measure period.																			
5	Counter did not properly totalize.																			
6	Problem with analog portion of trigger level.																			
7	Counter is not in proper state after being reset.																			
*OPC	Operation Complete	See note below.																		
*OPC?	Operation Complete Query	See note below.																		
*WAI	Wait to Complete	See note below.																		
*CLS	Clear Status	Clears all Status Registers.																		
*ESE	Event Status Enable	See note below.																		
*ESE?	Event Status Enable Query	See note below.																		
*ESR?	Event Status Register Query	See note below.																		
*SRE	Service Request Enable	Enables Status Register (see Chapter 4 for operation).																		
*SRE?	Service Request Enable Query	See note below.																		
*STB?	Read Status Byte Query	See note below.																		
*TRG	Bus Trigger	When the counter is in the wait-for-trigger state and the trigger source is TRIGger:SOURce BUS, use *TRG to trigger the counter.																		
*RCL	Recall Instrument State	See note below.																		
*SAV	Store Instrument State	See note below.																		

NOTE: These commands apply to many instruments and are not documented here in detail. See the *HP 75000 Series B Mainframe User's Manual* (HP Model Number E1300A/E1301A), the appropriate *Command Module User's Manual*, or the *ANSI/IEEE Standard 488.2-1987* for more information.

Command Quick Reference

The following tables summarize Standard Commands for Programmable Instruments (SCPI) commands and IEEE 488.2 Common (*) Commands for the HP E1333A 3-Channel Universal Counter.

SCPI Commands Quick Reference

Command	Description
ABORt	Place counter in idle state.
CONFigure :FREQuency [<i><range></i> [, <i><resolution></i>]] :NWIDth [<i><range></i> [, <i><resolution></i>]] :PERiod [<i><range></i> [, <i><resolution></i>]] :PWIDth [<i><range></i> [, <i><resolution></i>]] :RATio [<i><range></i> [, <i><resolution></i>]] :TINTerval [<i><range></i> [, <i><resolution></i>]] :TOTalize	Configure counter for frequency. Configure counter for negative pulse width. Configure counter for period. Configure counter for positive pulse width. Configure counter for ratio. Configure counter for time interval. Configure counter for totalize.
CONFigure?	Query counter configuration.
DISPlay :MONitor:CHANnel <i><channel AUTO></i> :MONitor:CHANnel? :MONitor[:STATe] <i><OFF 0 ON 1></i> :MONitor[:STATe]?	Monitor multiplexer channel. Query monitor channel. Enable/disable monitor mode. Query monitor mode.
FETCh?	Place measurement in output buffer.
INITiate	Place counter in wait-for trigger state.
INPut :ATTenuation <i><0 20 MIN MAX DEF></i> :ATTenuation? :COUPling <i><AC DC></i> :COUPling? :FILTer[:LPASs][:STATe] <i><OFF 0 ON 1></i> :FILTer[:LPASs][:STATe]? :IMPedance <i><50 1E6 MIN MAX DEF></i> :IMPedance?	Set channels 1 & 2 input attenuation. Query attenuation setting of channels 1 & 2. Set channels 1 & 2 input coupling. Query input coupling of channels 1 & 2. Enable/disable filter. Query if filter is enabled. Set channels 1 & 2 input impedance. Query impedance setting of channels 1 & 2.
MEASure :FREQuency? [<i><range></i> [, <i><resolution></i>]] :NWIDth? [<i><range></i> [, <i><resolution></i>]] :PERiod? [<i><range></i> [, <i><resolution></i>]] :PWIDth? [<i><range></i> [, <i><resolution></i>]] :RATio? [<i><range></i> [, <i><resolution></i>]] :TINTerval? [<i><range></i> [, <i><resolution></i>]]	Make frequency measurements. Make negative pulse width measurements. Make period measurements. Make positive pulse width measurements. Make ratio measurements. Make time interval measurements.
READ?	Counter in wait-for trigger state; readings in buffer.
[SENSe:] EVENT:LEVel <i><number MIN MAX DEF></i> EVENT:LEVel? [MIN MAX DEF] EVENT:SLOPe <i><POSitive NEGative></i> EVENT:SLOPe? FREQuency:APERture <i><time MIN MAX DEF></i> FREQuency:APERture? [MIN MAX DEF] FUNctioN: <i><function></i> FUNctioN? PERiod:NPERiods <i><number MIN MAX DEF></i> PERiod:NPERiods? [MIN MAX DEF] RATio:NPERiods <i><number MIN MAX DEF></i> RATio:NPERiods? [MIN MAX DEF] TINTerval:NPERiods <i><number MIN MAX DEF></i> TINTerval:NPERiods? [MIN MAX DEF]	Select event level. Query event level. Set event slope. Query event slope. Set gate time in seconds. Query aperture time. Select measurement function. Query measurement function. Set number of periods. Query number of periods. Set number of periods. Query number of periods. Set number of periods. Query number of periods.
STATus :QUESTionable:CONDition? :QUESTionable:ENABle <i><number></i> :QUESTionable:ENABle? :QUESTionable[:EVENT]?	Query the Questionable Condition Register. Set conditions in the Questionable Status. Query the Questionable Enable Register. Query the Questionable Event Register.

Continued on next page

SCPI Commands Quick Reference (continued)

Command	Description
SYSTem :ERRor?	Return error number/message from error queue.
TRIGger [:IMMediate] :SOURce BUS HOLD IMM :SOURce?	Trigger immediately. Specify trigger source. Query trigger source.

IEEE 488.2 Common Commands Quick Reference

Command	Title	Description																		
*RST	Reset	Sets FUNC:FREQ, INP:ATT 0, INP:COUP AC, INP:IMP 1 M Ω , INP:FILT OFF, RANGE AUTO, RESOLUTION 5 digits, APER 2 ms, NPER 2, EVEN:LEV 0, EVEN:SLOP POS, TRIG:SOUR IMM.																		
*TRG	Bus Trigger	When the counter is in the wait-for-trigger state and the trigger source is TRIG:SOUR BUS use the *TRG command to trigger the counter.																		
*TST?	Self-Test	Returns one of the following responses (numbers 0 through 7) after completing self-test. <table border="1" data-bbox="516 751 1445 982"> <thead> <tr> <th>Response</th> <th>Description</th> </tr> </thead> <tbody> <tr> <td>0</td> <td>Self-test passed.</td> </tr> <tr> <td>1</td> <td>Counter did not power up properly.</td> </tr> <tr> <td>2</td> <td>Problem with digital portion of trigger level.</td> </tr> <tr> <td>3</td> <td>Counter did not properly measure frequency.</td> </tr> <tr> <td>4</td> <td>Counter did not properly measure period.</td> </tr> <tr> <td>5</td> <td>Counter did not properly totalize.</td> </tr> <tr> <td>6</td> <td>Problem with analog portion of trigger level.</td> </tr> <tr> <td>7</td> <td>Counter is not in proper state after being reset.</td> </tr> </tbody> </table>	Response	Description	0	Self-test passed.	1	Counter did not power up properly.	2	Problem with digital portion of trigger level.	3	Counter did not properly measure frequency.	4	Counter did not properly measure period.	5	Counter did not properly totalize.	6	Problem with analog portion of trigger level.	7	Counter is not in proper state after being reset.
Response	Description																			
0	Self-test passed.																			
1	Counter did not power up properly.																			
2	Problem with digital portion of trigger level.																			
3	Counter did not properly measure frequency.																			
4	Counter did not properly measure period.																			
5	Counter did not properly totalize.																			
6	Problem with analog portion of trigger level.																			
7	Counter is not in proper state after being reset.																			

Appendix A

HP E1333A Specifications

Functions

Frequency Measurement

Minimum Pulse Width Channel 1 & 2: 5 nsec

Resolution: 1/Gate time

Accuracy: \pm resolution \pm timebase error \pm trigger noise error

Period Average Measurement

Channel 1 or 2 average 2^N periods of an input signal. Select the resolution directly in seconds or the number of periods to be averaged.

Period Range: μ sec - 6871 sec

Minimum Pulse Width: 60 nsec

Range of N: 1 to 16

Resolution: $1 / (10 \times 10^6 \times 2^N)$ sec

Accuracy: \pm resolution \pm timebase error \pm trigger noise error

Pulse Width (with average mode) Measurement

Minimum Pulse Width: 200 nsec

Maximum Pulse Width: $(6871/2^N)$ Sec

Range of N: 0 to 7

Resolution: $(100/2^N)$ nsec

Accuracy: \pm resolution \pm timebase error \pm trigger noise error

Time Interval (with average mode) Measurement

Measure the time interval between transitions from one channel to another channel. Select the resolution directly in seconds or the number of intervals, 2^N to be averaged. Select the rising or falling edge via software commands.

Minimum Interval: 200 nsec

Maximum Interval: $(6871/2^N)$ sec

Range of N: 0 to 7

Resolution: $(100/2^N)$ nsec

Accuracy: \pm resolution \pm timebase error \pm trigger noise error

Totalizing

Count the number of transitions on channel 1 & 2.

Minimum Pulse Width: 5 nsec

Range: 1 to $2^{36}-1$

Frequency Ratio Measurement

Measure the frequency ratio between channel 1 & 2 or channel 2 & 1. Select the resolution directly or the number of transitions, 2^N on one channel.

Minimum Pulse Width: 5 nsec

Range of N: 6 to 36

Resolution: $1 / 2^N$

Common Specifications

Time Base

Frequency: 10 MHz

Initial Accuracy: 2 ppm

Aging Rate: 2 ppm / year

Temperature Drift:

5 ppm, (0° to 50°C)

Trigger noise Error (RMS):

$$\frac{\sqrt{[(80\mu V)^2 + (E_n)^2]}}{\text{InputSlewRateatTriggerPoint}(\frac{\mu V}{sec})}$$

E_n: Noise on input signal for
150 MHz bandwidth

Channel 1 & 2

Frequency Range:

AC Coupled: 100 Hz to 100 MHz
DC Coupled: DC to 100 MHz

Coupling: Programmable AC or
DC coupled

Input Impedance (typical):

Programmable; 1 MΩ shunted by 50 pF
or 50 Ω

Filter:

Programmable Low Pass
Filter, 3 dB point at 100 kHz

Input Attenuator:

Programmable x1 or x10 attenuator

Input Range: (select the input attenuator)

Low Range: ±5 V
High Range: ±42 V

Trigger Level:

Low Input Range:
-2.56 V to 2.54 V in 20 mV step
High Input Range:
-25.6 V to 25.4 V in 0.2 V step

Trigger Level Accuracy:

Low Range:
±(10% level + 20 mV)
High Range:
±(10% level + 200 mV)

Input Level Sensitivity:

Low Input Range
(DC to 100 MHz): 25 mV
High Input Range
(DC to 100 MHz): 250 mV

Dynamic Range:

Low Input Range
(DC to 100 MHz): 43 dB
High Input Range
(DC to 100 MHz): 41 dB

Channel 3

Frequency Range:

75 MHz to 1 GHz,
prescaled by 64

Coupling: AC coupled

Input Impedance: 50 Ω

Input Range: ±5 V peak

Sensitivity:

75 MHz to 600 MHz: 10 mV
600 MHz to 900 MHz: 30 mV
900 MHz to 1 GHz: 40 mV

Dynamic Range:

75 MHz to 600 MHz: 51 dB
600 MHz to 900 MHz: 41 dB
900 MHz to 1 GHz: 39 dB

VSWR (typical):

1.5 @ 0 dBm

General

Module Size/Device Type:

B, register-based

Connectors Used: P1

No. Slots: 1

VXibus Interface Capability:

Interrupter, A16

Interrupt Level: 1-7, selectable

Power Requirements:

Voltage: +5 +12 -12
Peak module current, IPM(A):
0.50 0.15 0.15
Dynamic module current,
IDM(A): 0.02 0.01 0.01

Watts/Slot: 5.0

Cooling/Slot:

0.08 mm H₂O @ 0.42 liter/sec

Humidity: 65% 0° to 40°C

Operating Temperature:

0° to 55°C

Storage Temperature:

-40° to 75°C

EMC, RFI, Safety:

meets FTZ 1046/1984, CSA
556B, IEC 348, UL 1244

Net Weight (kg): 0.6

Appendix B

HP E1333A Universal Counter

Register-Based Programming

Using This Appendix

This appendix contains the information you need for register-based programming. The contents of this appendix are:

- About Register-Based Programming Page 107
- Addressing the Registers Page 107
- Register Definitions Page 111
- Register Descriptions Page 111
- Command Summary Page 115
- Register Programming Procedure Page 120
- Example Programs Page 125

About Register-Based Programming

The Universal Counter is a register-based module that allows you to read and write directly to the Counter's registers. When SCPI commands are used, the HP Command Module or HP Mainframe parses the commands and writes to the appropriate registers. Parsing is eliminated with register-based programming, increasing throughput speed. Register-based programming also allows the use of an embedded controller to access the VXIbus directly to increase throughput speed. The command module can be removed from a C-size mainframe if the slot 0 resource manager and the HP-IB computer interface are provided by another device.

Addressing the Registers

To access a specific register for either read or write operations, the address of the register must be known. Register addresses for the plug-in modules are found in an address space known as VXI A16. The exact location of A16 within a VXIbus master's memory map depends on the design of the VXIbus master you are using; for the HP E1300A/E1301A Mainframe and HP E1405A/E1406A Command Module, the A16 space location starts at 1F0000₁₆.

The A16 space is further divided so the modules are addressed only at locations above 1FC000₁₆ within A16. Further, every module is allocated 64 register addresses (40₁₆). The address of a module is determined by its logical address (set by the module's address switches) times 64 (40₁₆).

In the case of the HP E1333A module, the factory setting logical address is 48 or 30_{16} , so the addresses start at $C00_{16}$. Register addresses for register-based devices are located in the upper 25% of VXI A16 address space. Every VXI device (up to 256) is allocated a 64 byte block of addresses.

The Base Address

To read or write to specific registers, specify the register address. This address consists of a base address plus a register offset. The base address depends on whether the A16 address space is outside or inside the Series C HP E1406A Command Module or Series B HP E1300A/01A Mainframe.

A16 Address Space Outside the Command Module or Mainframe

When the command module or mainframe is not part of your VXIbus system, (Figure B-1), the counter's base address is computed as:

hexadecimal	decimal
$C000_{16} + (LADDR * 64)_{16}$	$49,152 + (LADDR * 64)$

where $C000_{16}$ (49,152) is the starting location of the register addresses, LADDR is the counter's logical address, and 64 is the number of address bytes per register-based module. For example, the counter's factory set logical address is 48. If this address is not changed, the counter will have a base address of:

hexadecimal	decimal
$C000_{16} + (48 * 64)_{16}$	$49,152 + (48 * 64)$
$C000_{16} + C00_{16} = CC00_{16}$	$49,152 + 3,072 = 52,224$

A16 Address Space Inside the Command Module or Mainframe

When the A16 address space is inside the command module or mainframe (Figure B-1), the counter's base address is computed as:

hexadecimal	decimal
$1FC000_{16} + (LADDR * 64)_{16}$	$2,080,768 + (LADDR * 64)$

where $1FC000_{16}$ (2,080,768) is the starting location of the register addresses, LADDR is the counter's logical address, and 64 is the number of address bytes per module. For example, the counter's factory set address is 48. If this address is not changed, the counter has a base address of:

hexadecimal	decimal
$1FC000_{16} + (48 * 64)_{16}$	$2,080,768 + (48 * 64)$
$1FC000_{16} + C00_{16} = 1FCC00_{16}$	$2,080,768 + 3,072 = 2,083,840$

Register Offset

The register offset is the register's location in the block of 64 address bytes (see Figure B-1). For example, the counter's Command Register has an offset of 08_{16} . When writing a command to this register, this offset is added to the base address to form the register address:

Address Space	Hexadecimal Register Address	Decimal Register Address
Outside the command module or mainframe	$CC00_{16} + 08_{16} = CC08_{16}$	$52,224 + 8 = 52,232$
Inside the command module or mainframe	$1FCC00_{16} + 08_{16} = 1FCC08_{16}$	$2,083,840 + 8 = 2,083,848$

The following table shows the general programming method for accessing the HP E1333A registers using different computers.

Computer	Programming Method	Base Address
E1300/E1301 IBASIC (Absolute Addressing) Select Code 8	READIO (-9826, Base_addr + offset) WRITEIO -9826, Base_addr + offset; data (positive select code = byte read or write negative select code = word read or write) READIO (8, Base_addr + reg number) WRITEIO 8, Base_addr + reg number; data	Base_addr = $1FC000_{16} + (LADDR * 64)_{16}$ or = $2,080,768 + (LADDR * 64)$ offset = register number Base_addr = $LADDR * 256$ reg number = offset
External Computer (over HP-IB to E1300/E1301 Mainframe or E1406 Command Module)	VXI:READ? logical_address, offset VXI:WRITE logical_address, offset, data DIAG:PEEK? Base_addr + offset, width DIAG:POKE Base_addr + offset, width, data	Module Logical Address setting (LADDR) offset = register number Base_addr = $1FC000_{16} + (LADDR * 64)_{16}$ or = $2,080,768 + (LADDR * 64)$ offset = register number
V/360 Embedded Computer (C-Size system)	READIO (-16, Base_addr + offset) WRITEIO -16, Base_addr + offset; data (positive select code = byte read or write negative select code = word read or write)	Base_addr = $C000_{16} + (LADDR * 64)_{16}$ or = $49,152 + (LADDR * 64)$ offset = register number
LADDR is the E1333A Logical Address = 48 ($LADDR * 64)_{16}$ = multiply quantity then convert to hexadecimal number (e.g. $(80 * 64)_{16} = (960)_{16} = 1400_{16}$ When using DIAG:PEEK? and DIAG:POKE, the width must be either 8 or 16.		

Figure B-1 shows the Universal Counter register address location within A16 when the command module or mainframe address space is not used. It also shows the location of A16 address space in the HP E1405A/06A Command Module and HP E1300A/01A Mainframe. Note the addressing difference.

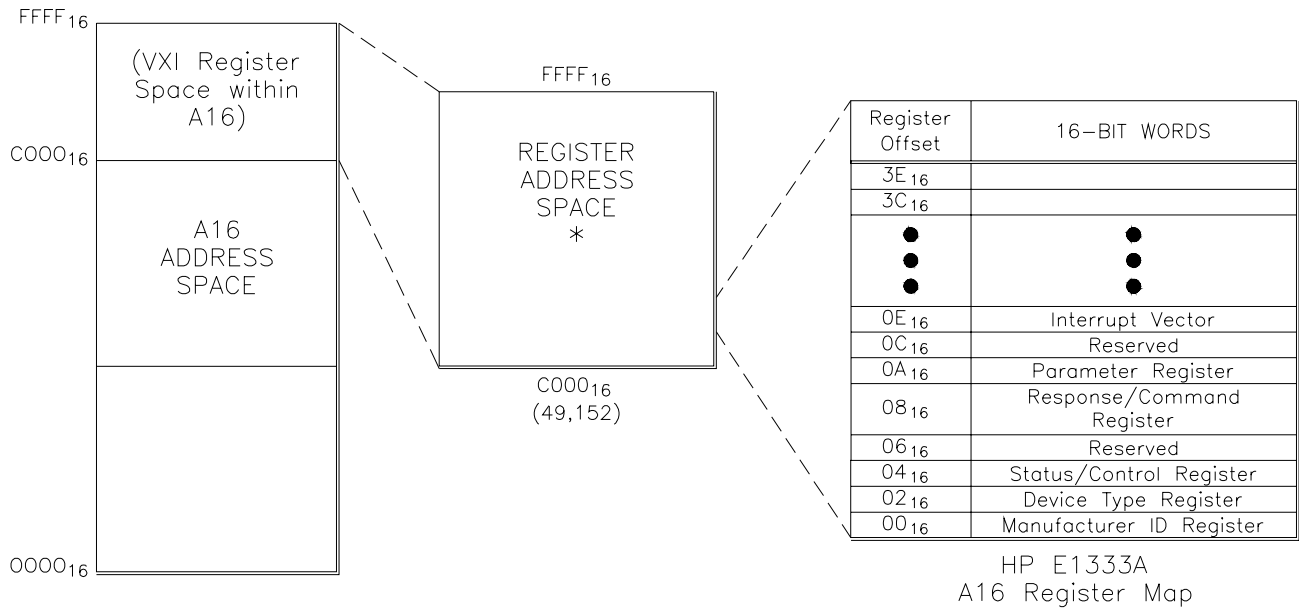

*Base Address = C000₁₆ + (Logical Address * 64)₁₆
 or
 49,152 + (Logical Address * 64)₁₀

Register Address = Base address + Register Offset

A24 Address Space Internal to Mainframe (Series B HP E1300A)
 or Command Module (Series C HP E1405A)

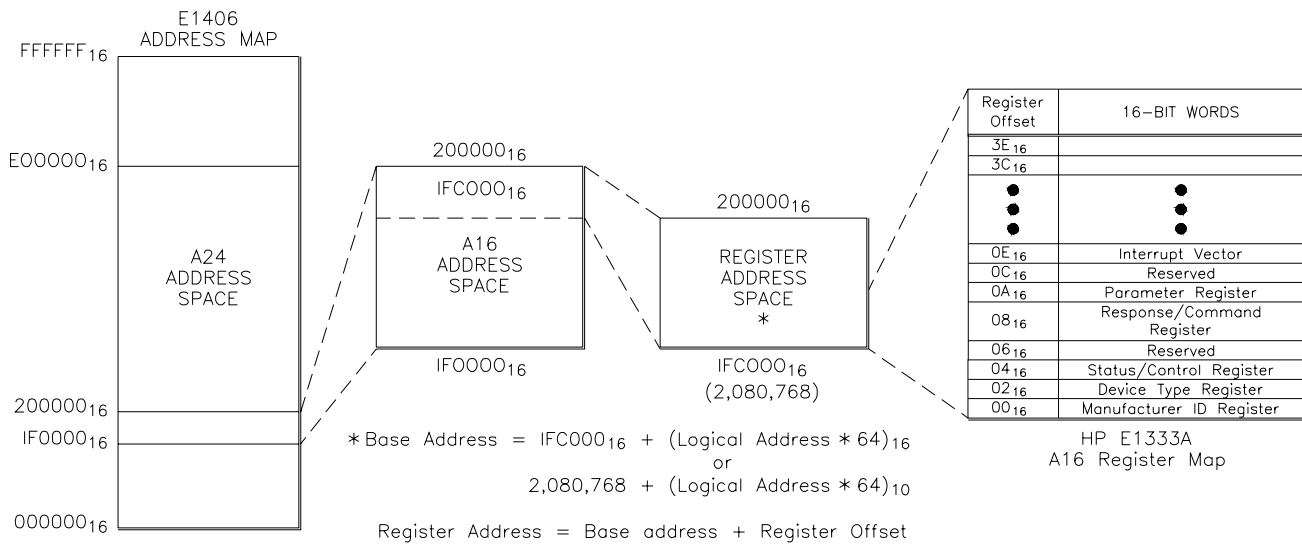

*Base Address = IF0000₁₆ + (Logical Address * 64)₁₆
 or
 2,080,768 + (Logical Address * 64)₁₀

Register Address = Base address + Register Offset

Figure B-1. Universal Counter Registers within A16 Address Space

Register Definitions

You can program the HP E1333A Universal Counter using its hardware registers. *The procedures for reading or writing to a register depend on your operating system and programming language.* Whatever the access method, you will need to identify each register by its address. These addresses are given in Table B-1.

Table B-1. Universal Counter Addressable Registers

Register Offset	READ Registers	WRITE Registers
00 ₁₆	Manufacturer ID Register	undefined
02 ₁₆	Device Type Register	undefined
04 ₁₆	Status Register	Control Register
06 ₁₆	reserved	reserved
08 ₁₆	Response Register	Command Register
0A ₁₆	undefined	Parameter Register
0C ₁₆	reserved	reserved
0E ₁₆	Interrupt vector	undefined

The module is a register-based slave/interrupter device, supporting VME D16, D8(O), and D8(OE) transfers. The interrupt protocol supported is "release on Register access" - an interrupt is cleared only by servicing the cause of the interrupt (generally by reading or writing a byte of data). Interrupts are not cleared by a VXIbus interrupt acknowledge cycle.

Register Descriptions

The following pages detail register descriptions for the HP E1333A Universal Counter.

Manufacturer ID Register

The Manufacturer Identification Register is a read-only register at address 00₁₆ (Most Significant Byte (MSB)) and 01₁₆ (Least Significant Byte (LSB)). Reading this register returns the Hewlett-Packard identification.

base + 00 ₁₆	15	14	13	12	11	10	9	8	7	6	5	4	3	2	1	0
WRITE	Undefined															
READ	Manufacturer ID (all 1's = FFFF ₁₆ = Hewlett Packard A16 register-based)															

(00₁₆ = register offset; see "Addressing the Registers" on page 107)

Device Type Register

The Device Type Register is a read-only register accessed at address 02₁₆. Reading this register returns the Universal Counter Module Identification of 64₁₆. Reading address 03 always returns FF₁₆.

base + 02 ₁₆	15	14	13	12	11	10	9	8	7	6	5	4	3	2	1	0
WRITE	Undefined															
READ*	1	1	1	1	1	1	1	1	0	1	1	0	0	1	0	0

*Returns FF64₁₆ = Device type code for HP E1333A 3-Channel Universal Counter

Status (READ)/ Control (WRITE) Register

The module Status/Control register is a read/write register accessed at address 04₁₆ and 05₁₆. The following table shows the register bit patterns.

base + 04 ₁₆	15	14	13	12	11	10	9	8	7	6	5	4	3	2	1	0
WRITE*	Ignored								X	X	X	X	X	X	SYS/FAIL	RESET
READ	1	1	1	1	1	1	1	1	DON	X	X	X	X	TST	QRR	RDY

*Refer to the table below for an explanation of the bits.

Three bits (0, 1, and 7) of the eight bit Status Register (register 04₁₆) provide information on the operational status of the Counter.

Bit No.	Bit Mnemonic	Comments
0	RDY	A one (1) indicates the counter's data buffer is empty and that data may be written to the Command Register (08 ₁₆) or the Parameter Register (0A ₁₆).
Bit 0 must be high (1) for bit 7 to be valid.		
7	DON	A one (1) indicates that the previous command and parameter have been processed. Writing to the Command Register (08 ₁₆) when this bit is zero (0) may abort the command in progress.
Bit 7 must be high (1) for bit 1 to be valid.		
1	QRR	A one (1) in this field indicates that the Response Register (08 ₁₆) is loaded and ready to be read.
2	TST	A one (1) indicates Self Test passed, a zero (0) indicates the self test is in progress or has failed.

You can write to the Control Register to disable the counter from driving the SYSFAIL line and then reset the Counter. Bit 1 controls inhibiting system fail and bit 0 controls the reset. Both bits are HIGH true. The Counter is held in reset mode as long as bit 0 is held high. Normal operation begins when this bit is returned to the low state. The following causes a reset:

1. Write 02₁₆ to the control register to inhibit the SYSFAIL line.
2. Write 03₁₆ to the control register to keep SYSFAIL inhibited and initiate the reset mode (reset starts when bit 0 goes low).

3. Wait 10 microseconds.
4. Write 02₁₆ to the control register to set the RESET bit low and start the reset.
5. When bit 2 (TST) of the Status Register is high, the counter has passed self-test.
6. Write 00₁₆ to the Control Register to enable the drive of the SYSFAIL line.

NOTE: It is recommended you reset the counter using register command 15.

Command (WRITE)/ Response (READ) Register

Register 08₁₆ is the Query Response Register. This register contains the measurement data obtained by using the Read Channel command (command 14) or the response from the Read Status command (command 13).

base + 08 ₁₆	15	14	13	12	11	10	9	8	7	6	5	4	3	2	1	0
WRITE*	1	1	1	1	1	1	1	1	1, 2, 3, 4, 5, 6, ** 10, 12, 13, 14, or 15							
READ	ignored								data bits for measurement or status query							

*Refer to "Register Command 13" or to "Computing the Answer" later in this appendix for response information.
** 7, 8, and 9 are no-op conditions.

There are eleven register-based commands (the commands are numbers) used for setting up signal conditioning, making measurements, reading the measurement data, and reading the state of the counter. Each command must be followed by a parameter to complete the command. Commands are written to the Command Register and parameters are written to the Parameter Register. Bit 0 (RDY) of the Status Register must be high before you can write to the Command or Parameter Register and not abort the previous command in process.

Command List

Command	Description	Required Parameter
1	Event level 1	Sets event level on channel 1.
2	Event level 2	Sets event level on channel 2.
3	Input conditioning	Sets Channel 1 & 2 input parameters.
4	Measure frequency	Sets channel no. and gate time.
5	Measure Period	Sets channel no. & number of cycles.
6	Measure pulse width or time interval	Sets channel no., channel polarity, and repeat factor.
10	Totalize	Sets channel no. and internal/external.
12	Measure ratio	Sets ratio factor and number of cycles.
13	Read status	Specifies the type of status request.
14	Read channel	Sets the channel that will be read.
15	Reset	Only needed to complete the reset.

Parameter Register

Register 0A₁₆ is the Command Parameter Register. Commands are not processed until the required number of parameters are received. A command is ignored if a new command is sent before the required number of parameters are sent for the first command. If a second command is sent before the first command completes execution, the first command may only partially complete.

base + 0A ₁₆	15	14	13	12	11	10	9	8	7	6	5	4	3	2	1	0
WRITE	1	1	1	1	1	1	1	1	Required parameter							
READ	Ignored															

Interrupt Vector Register

Register 0E₁₆ is the Interrupt Vector Register. Either bit 8, 9, 10, or 11 is set LOW when the function associated with the bit has completed a measurement. The bit-function association is as follows:

- Bit 8 Frequency (FREQ) complete
- Bit 9 Period (PER) complete
- Bit 10 Ratio (RAT) complete
- Bit 11 Time Interval (TINT) complete

These four functions pull the interrupt line. Read the interrupt vector to see which function has completed and then read the measurement data.

base + 0E ₁₆	15	14	13	12	11	10	9	8	7	6	5	4	3	2	1	0
WRITE	Undefined															
READ	1	1	1	1	TINT	RAT	PER	FREQ	Bits 7 - 0 are ignored							

Interrupt Requests

The module generates an interrupt request by pulling the interrupt line set by the IRQ jumpers (IRQ1 through 7). The module generates an interrupt when the measurement is complete (a response interrupt). An interrupt handler within the mainframe services the interrupt. Actual servicing of the interrupt begins when the handler obtains the data transfer bus because the logical address and status of the module is read by the handler over this bus.

The handler drives the interrupt acknowledge line (IACK*) low and broadcasts a 3-bit interrupt acknowledge code over the three least significant address lines. The slot 0 module (controller) generates an interrupt acknowledge through a daisy-chained line to all modules in the mainframe, one at a time. If a module has generated an interrupt, it reads the lower three address lines to verify the code matches the level of interrupt it generated (for example IRQ1). If the interrupt code matches, the interrupt handler reads a 16-bit word from the data transfer bus containing the module's logical address (bits 0-7) and the status or cause of the interrupt (bits 8-15). The E1333A Universal Counter reports an event or a cause which is a measurement complete and is specified by the Interrupt Vector Register shown previously (some other modules may report the status byte).

Command Summary

Register Command 1 Command 1 sets the event level for channel 1. The event level can be set to 256 different levels in 20 millivolt steps from -2.56V to +2.54V using the parameter.

Parameter This command requires one (1) parameter (a two's compliment number) to set the level. There are 256 choices from 00₁₆ to FF₁₆.

FF₁₆ = +2.54, FE₁₆ = +2.52...
 81₁₆ = +0.02, 80₁₆ = 0.00, 7F₁₆ = -0.02...
 01₁₆ = -2.54, 00₁₆ = -2.56

Register Command 2 Command 2 sets the event level for channel 2. The event level can be set to 256 different levels in 20 millivolt steps from -2.56V to +2.54V using the parameter.

Parameter This command requires one (1) parameter (a two's compliment number) to set the level. There are 256 choices from 00₁₆ through FF₁₆.

FF₁₆ = +2.54, FE₁₆ = +2.52...
 81₁₆ = +0.02, 80₁₆ = 0.00, 7F₁₆ = 0.02...
 01₁₆ = -2.54, 00₁₆ = -2.56

Register Command 3 Command 3 sets the input signal conditioning (LP filter, attenuation, coupling, impedance) with bits 0, 1, 2, and 3 of the parameter byte. This command requires one (1) parameter.

Parameter

	BIT NUMBER							
	7	6	5	4	3	2	1	0
0	X	X	X	X	100 MHz	DIV. 1	AC	1 Mohm
1	X	X	X	X	100 kHz	DIV. 10	DC	50 ohms

Register Command 4

Command 4 performs a frequency measurement. This command requires one (1) parameter which specifies the channel for the measurement and the gate time. Bits 0, 1, 2, and 3 specify the gate time. Bits 4 and 5 specify the channel or internal 10 MHz.

Parameter

BIT NUMBER							
7	6	5	4	3	2	1	0
X	X	Channel #: 00 = Chan 1 01 = Chan 2 10 = Chan 3 11 = Internal 10 MHz		Gate time (16 steps): 0000 = 2 msec 0001 = 4 msec 1110 = 32768 msec 1111 = 65536 msec			

Register Command 5

Command 5 performs a period measurement. This command requires one (1) parameter which specifies which channel to measure on and the number of cycles to average for the measurement. Bits 0, 1, 2, and 3 specify the number of cycles. Bits 4 and 5 specify the channel or internal 10 MHz.





Parameter

BIT NUMBER							
7	6	5	4	3	2	1	0
X	X	Channel #: 00 = Chan 1 01 = Chan 2 10 = Undefined 11 = Internal 10 MHz		Number of cycles (16 steps): 0000 = 2 cycles 0001 = 4 cycles - 1110 = 32768 cycles 1111 = 65536 cycles			

Register Command 6

Command 6 makes a time interval measurement. This can be a one-time measurement or it can be repeated a specified number of times on a repetitive input waveform. The required parameter contains three bits (bits 4, 5, and 6) to give you eight choices of a repeat factor. The parameter also contains two bits (bits 2 and 3) used to specify the polarity of the pulse width or start and stop edge. Additionally, the parameter contains two bits (bits 0 and 1) that specify the start channel and stop channel for a time interval measurement.

Parameter

	BIT NUMBER							
	7	6	5	4	3	2	1	0
0	X	Repeat factor: 000 = 1 001 = 2 010 = 4 011 = 8 100 = 16 101 = 32 110 = 64 111 = 128			1 Polarity 	2 Polarity 	Channel numbering: Start-Stop channels 00 = 1-1* 01 = 2-2* 10 = 1-2 11 = 2-1	
1	X				1 Polarity 	2 Polarity 	* = single channel measurement	

Some possible choices are shown below with a repeat factor of 1:

*Positive pulse width of channel 1 X000 0X00

*Negative pulse width of channel 1 X000 1X00

*Positive pulse width of channel 2 X000 X001

*Negative pulse width of channel 2 X000 X101

Time interval 1 rising to 2 rising X000 0010

Time interval 2 rising to 1 rising X000 0011

Time interval 1 falling to 2 rising X000 1010

Time interval 2 falling to 1 rising X000 0111

NOTE: not all combinations are illustrated.

Register Command 10

Command 10 will totalize events. A single parameter is sent to specify which channel is to totalize and whether to totalize an external input or totalize the 10 MHz internal clock as a test. Bit 0 specifies whether you totalize on channel 1 or channel 2. Bit 1 specifies whether you totalize the internal 10 MHz signal or an external input. The accumulated count can be read repeatedly. The counter is not reset when the channel is read so repetitive reading will give the cumulative total. If more than 2^{36} events are counted, the overflow bit is set on the first overflow. The counter rolls over and continues the count but the overflow bit will remain set following the first overflow until the channel is reprogrammed.

Parameter

	BIT NUMBER							
	7	6	5	4	3	2	1	0
0	X	X	X	X	X	X	External	Channel 1
1	X	X	X	X	X	X	Internal 10 MHz	Channel 2

Register Command 12

Command 12 makes a ratio measurement. A single parameter is used to specify how many cycles are to be counted and whether the ratio is Channel 1/Channel 2 or Channel 2/Channel 1. Bit 0 specifies the ratio of Channel 1/Channel 2 or the inverse. Bits 2 through 6 specify the number of cycles for the measurement.

Parameter

	BIT NUMBER							
	7	6	5	4	3	2	1	0
0	X	Bits 6-5-4-3-2 specify no. of cycles: 00000 = 1 cycle 00001 = 2 ⁶ cycles 00010 = 2 ⁷ cycles, . . . 11110 = 2 ³⁵ , 11111 = 2 ³⁶					X	Ratio of Chan 1/Chan 2
1	X						X	Ratio of Chan 2/Chan 1

Register Command 13

Command 13 reads the status of the counter. The requested information is entered into the response register 08₁₆. A single parameter specifies the type of status request defining the information that is returned.

Parameter	Type of Status Request/Information Returned
1	Function that the card was last asked to do. Channel the function is programmed for. Gate time, number of periods, intervals, or cycles for function.
2	
3	
5	Programmed level for channel 1. Programmed level for channel 2. Input signal conditioning settings.
6	
7	

The next table provides complete detail on the data that is returned for each of the above parameters. For example, if parameter 1 is sent, a return of 10₁₆ indicates the function last asked was period. If you follow this with command 13 parameter 2, the return will tell you which channel made the measurement or if the internal 10 MHz was measured. Parameter 3 will tell you the number of periods that were averaged.

Parameter 1 Returns	Parameter 2 Returns	Parameter 3 Returns						
00 ₁₆ = FREquency	00 ₁₆ = Channel 1 01 ₁₆ = Channel 2 02 ₁₆ = Channel 3 03 ₁₆ = 10 MHz	Gate Time: 00 ₁₆ = 2 msec 01 ₁₆ = 4 msec 02 ₁₆ = 8 msec . . . 0E ₁₆ = 32.768 sec 0F ₁₆ = 65.536 sec						
10 ₁₆ = PERiod	00 ₁₆ = Channel 1 01 ₁₆ = Channel 2 02 ₁₆ = Undefined 03 ₁₆ = 10 MHz	Periods averaged: 00 ₁₆ = 2 01 ₁₆ = 4 02 ₁₆ = 8 . . . 0E ₁₆ = 32768 0F ₁₆ = 65536						
30 ₁₆ = TINTerval	00 ₁₆ = P PW Channel 1 01 ₁₆ = P PW Channel 2 02 ₁₆ = TI 1R 2R 03 ₁₆ = TI 2R 1R 04 ₁₆ = P PW Channel 1 05 ₁₆ = N PW Channel 2 06 ₁₆ = TI 1R 2F 07 ₁₆ = TI 2F 1R 08 ₁₆ = N PW Channel 1 09 ₁₆ = P PW Channel 2 0A ₁₆ = TI 1F 2R 0B ₁₆ = TI 2R 1F 0C ₁₆ = N PW Channel 1 0D ₁₆ = N PW Channel 2 0E ₁₆ = TI 1F 2F 0F ₁₆ = TI 2F 1F	Number of time intervals or pulses to average over: 00 ₁₆ = 1 01 ₁₆ = 2 02 ₁₆ = 4 03 ₁₆ = 8 04 ₁₆ = 16 05 ₁₆ = 32 06 ₁₆ = 64 07 ₁₆ = 128						
50 ₁₆ = TOTalize	00 ₁₆ = Channel 1 01 ₁₆ = Channel 2 02 ₁₆ = 10 MHz Channel 1 03 ₁₆ = 10 MHz Channel 2	Not used (always 0)						
90 ₁₆ = Not programmed	Not used (always 0)	Not used (always 0)						
C0 ₁₆ = RATio	00 ₁₆ = Ratio factor of Channel 1 to Channel 2 01 ₁₆ = Ratio factor of Channel 2 to Channel 1	00000 = 1 cycle 00001 = 2 ⁶ cycles . . . 11110 = 2 ³⁵ cycles 11111 = 2 ³⁶ cycles						
Parameter 5 and 6 Returns: trigger level set by command 1 or 2 as a two's compliment number. See commands 1 and 2 for definition of returned value.								
Parameter 7 Returns: signal conditioning data set by command 3 (or the default values) according to the following bit pattern:								
	BIT NUMBER							
	7	6	5	4	3	2	1	0
0	X	X	X	X	100 MHz	Divide by 1	AC	1 Mohm
1	X	X	X	X	100 kHz	Divide by 10	DC	50 ohms

Register Command 14

Command 14 reads a single channel and the result depends on what that channel had been programmed to do. A single parameter, using bits 0 and 1, specifies the channel to be read.

- The result is returned in 6 bytes. The first 5 bytes are the mantissa. The 6th byte is the exponent. The result must be constructed from these six bytes. Programs demonstrating how to do this are given at the end of this appendix.
- For counting (totalize - command 10), the exponent is zero (80_{16}).
- For frequency, the exponent will tell how many bits to shift to give an answer in Hertz.
- For time interval, pulse width, or period, the exponent will tell how many bits to shift to give the result in seconds.
- For overflow, bit 7 of the first byte will be 1; the remainder will be the answer as read.
- For a channel that is not programmed, the result will be all 1's.

Parameter

BIT NUMBER							
7	6	5	4	3	2	1	0
X	X	X	X	X	X	Channel number:	00 = channel 1 01 = channel 2 10 = channel 3 11 = undefined

Register Command 15

Command 15 resets the counter to the power-on condition. The command must include a parameter. What is sent for the parameter is not important. The parameter for command 15 can be anything (for example, send 0). The reset action starts when the parameter is received.

Register Programming Procedure

The procedure described below shows the STATUS bit states required before writing to or reading from the registers. The procedure shows the sequence used to execute a command/parameter and how to detect when a measurement is complete followed by reading back the data.

1. Check the STATUS byte bits 0 and 7 to verify that the input buffer is empty and the previous command will not be aborted.
 - Check that STATUS bit 0 is high (command/parameter ready bit) to verify that the input buffer is empty and the command register can be written to.
 - Check that STATUS bit 7 is high (DONE) which indicates the module has processed the previous command.
 - If you want to abort a command before the parameter is sent or abort a command in process, you can simply write a new command to the command register. The first command will be aborted and the command sent last is processed and executed.

- To keep from losing measurement data, you must retrieve the data from the previous command execution before sending a new command. Sending a command destroys previous data from all channels with the exception of the totalize function if the previous command was also totalize. For example, if channel 1 is programmed for totalize, subsequently programming channel 2 for totalize will not destroy the cumulative counting of channel 1 or vice versa.
2. SEND COMMAND TO COMMAND REGISTER. Write the opcode to the command register (Register 08₁₆).
 - Check that STATUS bit 0 is high (command/parameter ready). The input buffer must be empty for the parameter to be recognized.
 3. SEND PARAMETER TO PARAMETER REGISTER. Write parameter to parameter register (Register 0A₁₆).
 - All commands are executed after the parameter is accepted.
 - For a command that does not return data e.g., set trigger level, set input conditioning, or reset, the command is executed and no further programming for the command is required. Continue with this procedure for commands that return data.
 - IF THE COMMAND SENT IS A TYPE THAT RETURNS DATA AND INTERRUPTS WHEN THE MEASUREMENT IS COMPLETE (frequency, period, ratio, time interval), CONTINUE WITH STEP 4. IF THE COMMAND RETURNS DATA BUT DOES NOT INTERRUPT (totalize or read status), CONTINUE WITH STEPS 12 or 13.
 4. WAIT FOR INTERRUPT. Wait for the counter to pull the interrupt line. See the following note!

Note

Do not poll the interrupt vector (register 0E₁₆) to detect measurement complete because this may cause noise on the card while measuring small signal levels.

5. CHECK WHICH PROCESS HAS COMPLETED. Read register 0E₁₆ (interrupt vector) to determine which process completed (check the bit associated with function performed).
 - Check that STATUS bit 0 is high (command/parameter ready).
6. READ THE CHANNEL THAT MADE THE MEASUREMENT. Write command 14 (READ CHANNEL) to command register 08₁₆.
 - Check that STATUS bit 0 is high (command/parameter ready).
7. SEND PARAMETER TO TELL WHICH CHANNEL TO READ. Write to parameter register 0A₁₆ to tell which channel to read.

- Check that STATUS bit 0 is high (command/parameter ready) and bit 7 is high (DONE). Bit 7 indicates the command has been processed. Bit zero (0) must be true for bit 7 to be valid.
8. CHECK THAT THE QUERY RESPONSE REGISTER HAS BEEN LOADED BY DOING THE FOLLOWING:
 - Check that STATUS bit 1 is high for query response register ready (indicates data has been put into the query response register and can be read).
 9. READ THE DATA FROM THE COUNTER. The measurement or count is in six (6) bytes so response register 08₁₆ must be read six times.
 - a) Read the query response register (register 08₁₆)
 - b) Enter the data (data is in the lower 8 bits)
 - c) BINAND data with 255 (masks bits 8 and above)
 10. Repeat step 8 and 9 five more times (measurement is in 6 bytes and you must verify that the query response register has been loaded for each byte).
 11. Calculate the answer. See the following section “Computing the Answer”.
 - Steps 12 and 13 are for commands that return data but do not pull the interrupt when the command completes as do measurement commands 4, 5, 6, and 12.
 12. IF THE COMMAND EXECUTED IS "TOTALIZE", the current total (six bytes) can be read anytime by executing steps 6 - 11.
 13. IF THE COMMAND IS "READ STATUS", a single byte is returned by executing steps 6 through 8 and reading one data byte.

Computing the Answer

Enter six words of data (the upper byte of each word is always ignored) from the query response register (A(1), A(2), A(3), A(4), A(5), and A(6)). The lower byte of the first five words are the mantissa of the data, the lower byte of the sixth word, A(6), is the exponent of the data.

Checking For Overflow

Bit 7 of the first word, A(1), when set high after a measurement or count, tells you if the counter has overflowed. For a measurement such as frequency, period, time interval, or ratio, the measurement data is invalid. If the counter is totalizing events (totalize function), bit 7 is set high after the counter rolls over the first time (exceeds a count of 2^{36}). The count from the other bits is still valid but you must keep track of the number of times the counter rolls over to keep an accurate cumulative count. Bit 7 remains set high for subsequent counting and overflows and you must detect these overflows by comparing the present count to previous counts.

Constructing the Answer

Construct the answer "Final" with the following procedure:

1. Check for overflow by checking that bit 7 of the first word is high. DO NOT destroy bits 0 through 6. If the function is totalize, these bits provide valid count data. If bit 7 is set and the function is not totalize, data is invalid.

First data word A(1): (part of mantissa)

BIT NUMBER															
15	14	13	12	11	10	9	8	7	6	5	4	3	2	1	0
Bits 15 - 8 are ignored								**	data bits						

** = overflow bit

Second through fifth data words A(2) - A(5): (part of mantissa)

BIT NUMBER															
15	14	13	12	11	10	9	8	7	6	5	4	3	2	1	0
Bits 15 - 8 are ignored								data bits							

Sixth data word A(6): (exponent)

BIT NUMBER															
15	14	13	12	11	10	9	8	7	6	5	4	3	2	1	0
Bits 15 - 8 are ignored								data bits							

2. Remove the upper byte of each word. Binary AND the first word A(1) with 127 (masks bits 7 and above) and each remaining word with 255 (masks bits 8 and above).
3. Final = $(A(1)*2^{32} + A(2)*2^{24} + A(3)*2^{16} + A(4)*2^8 + A(5)) * 2^{(A(6)-128)}$

The exponent is the value $2^{(A(6)-128)}$.

Register Programming Flowchart

This section provides a flowchart of the process used to make a measurement with a command that returns data and pulls the interrupt after completing the measurement. The flowchart shows execution of the command and then retrieval of the data.

Make Measurement

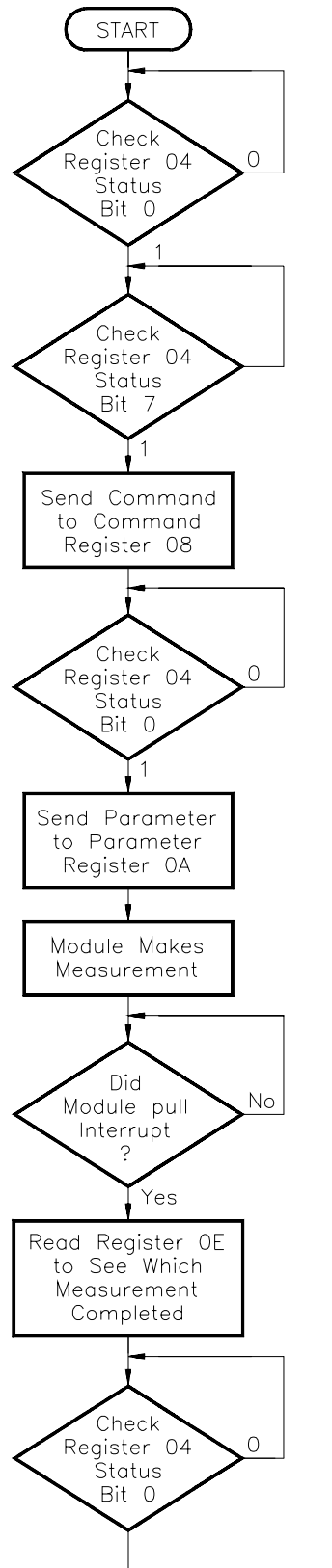

Read Data

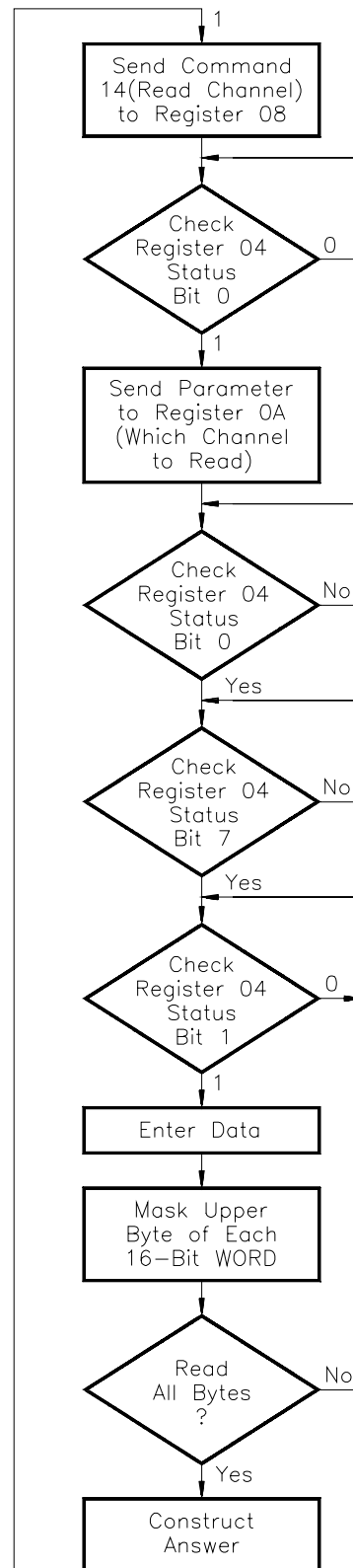

Programming Examples

The examples in this section demonstrate how to program the module at the register level. The programs follow the execution and timing models covered in the previous section. The examples in this section include:

- Resetting the Counter
- Reading the ID, Device Type, and Status Registers
- Programming the Counter to make a measurement
- Embedded Controller Programming Example

Resetting the Counter

The following programs reset the HP E1333A Counter. The programs send Register Command 15 to the Command Register (register 8); wait until the Status Register indicates the module is ready (Bit 0 of the Status Register); then writes a 0 to the Parameter Register (Register 10).

HP IBASIC Version

```
10 Base_addr = DVAL("1FCC00",16)
20 WRITEIO -9826, Base_addr + 8; 15
30 REPEAT
40     UNTIL BIT(READIO(-9826, Base_addr + 4), 0)
50 WRITEIO -9826, Base_addr + 10; 0
60 WAIT 1
70 END
```

C Version

```
    /* reset the module */

#include <stdio.h>
#include <chpib.h>
#define LOG_ADDR 48
#define BASE_ADDR (long) ((0x1FC000) + (64 * LOG_ADDR))
main ()
{
    int reg_addr;
    /* send the data to the command register */
    reg_addr = 8;                /* Offset for Cmd Register */
    send_the_data (BASE_ADDR + reg_addr, 15);
    /* wait for RDY bit (bit 0) to go true */
    reg_addr = 4;                /* Offset for Status Register */
    wait_not_busy (BASE_ADDR + reg_addr);
    /* send the parameter to the parameter register */
    reg_addr = 10;               /* Offset for Parameter Reg */
    send_the_data (BASE_ADDR + reg_addr, 0);
    return 0;
}
```

```

        /* Function to actually send the data to the module */
send_the_data (long register_address, int register_data)
{
    float    send_data[3];
    char    state[2] = {13,10};
    send_data[0] = register_address;
    send_data[1] = 16;
    send_data[2] = register_data;

    IOEOI (7L, 0); IOEOL (7L, " ", 0);
    IOOUTPUTS (70900L, "DIAG:POKE ", 10);
    IOEOI (7L, 1); IOEOL (7L, state,0);
    IOOUTPUTA (70900L, send_data, 3);

    return 0;
}

        /* wait for module to finish */
wait_not_busy (long register_address)
{
    float    send_data[3], read;
    long    bit_number;
    char    state[2] = {13,10};
    send_data[0] = register_address;
    send_data[1] = 16;
    send_data[2] = 0;
    IOEOI (7L, 0); IOEOL (7L, " ", 0);
    IOOUTPUTS (70900L, "DIAG:PEEK? ", 11);
    IOEOI (7L, 1); IOEOL (7L, state, 2);
    IOOUTPUTA (70900L, send_data, 2);
    while (bit_number != 1)
    {
        IOENTER(70900L, &read);
        bit_number = ((long)(read)&1);
    }
    return 0;
}

```

Reading the ID, Device Type, and Status Registers

The following examples read the module ID, DEVICE TYPE, and STATUS registers from the module. The program should return the following values:

Identification Register : FFFF₁₆
Device Type Register: FF64₁₆
Status Register (value may vary depending on actual status): FFCD₁₆

HP IBASIC Version

```
10      !*****
20      !*****          READREG          *****
30      !*****
40      !OPTION BASE 0 is default
50      !Set up arrays to store register names and addresses
60      DIM Reg_name$(1:3)[32], Reg_addr(1:3)
70      !
80      !Read register names and addresses into the arrays
90      READ Reg_name$(*)
100     READ Reg_addr(*)
110     !
120     !Set base Address variable
130     Base_addr = DVAL ("1FCC00",16)
140     !
150     !Map the A16 address space
160     !
170     !CONTROL 16,25;2 ! used only with V360 Controller
180     !Call the subprogram Read_regs
190     Read_regs(Base_addr, Reg_name$(*),Reg_addr(*))
200     !
210     DATA Identification Register, Device Register, Status Register
220     DATA 00, 02, 04
230     END
300     !This subprogram steps through a loop that reads each register and
        prints its contents
310     !
320     SUB Read_regs(Base_addr, Reg_name$(*),Reg_addr(*))
330     !
340     FOR Number = 0 to 2
350     Register = READIO(-9826,Base_addr + Reg_addr(number))
360     PRINT Reg_name$(number);" = "; IVAL$(Register, 16)
370     NEXT Number
380     SUBEND
```

C Version

```
/* read registers */
#include <stdio.h>
#include <chplib.h>
#define LOG_ADDR 48
#define BASE_ADDR (long) ((0x1FC000) + (64 * LOG_ADDR))
main()
{
    int    reg_addr;
    float  send_data[3], read;
    char   state[2] = {13,10};

    send_data[1] = 16;
    send_data[2] = 0;
    send_data[0] = BASE_ADDR + 0;

    /* Read the Identification Register - reg. offset = 0 */
    IOEOI (7L, 0); IOEOL (7L, " ", 0);
    IOOUTPUTS (70900L, "DIAG:PEEK? ", 11);
    IOEOI (7L, 1); IOEOL (7L, state, 2);
    IOOUTPUTA (70900L, send_data, 2);
    IOENTER(70900L, &read);
    printf("\nIdentification Register = %0x", (int)read);

    /* Read the Device Type Register - reg. offset = 2 */
    send_data[0] = BASE_ADDR + 2;
    IOEOI (7L, 0); IOEOL (7L, " ", 0);
    IOOUTPUTS (70900L, "DIAG:PEEK? ", 11);
    IOEOI (7L, 1); IOEOL (7L, state, 2);
    IOOUTPUTA (70900L, send_data, 2);
    IOENTER(70900L, &read);
    printf("\nDevice Type Register = %0x", (int)read);

    /* Read the Status Register - reg. offset = 4 */
    send_data[0] = BASE_ADDR + 4;
    IOEOI (7L, 0); IOEOL (7L, " ", 0);
    IOOUTPUTS (70900L, "DIAG:PEEK? ", 11);
    IOEOI (7L, 1); IOEOL (7L, state, 2);
    IOOUTPUTA (70900L, send_data, 2);
    IOENTER(70900L, &read);
    printf("\nStatus Register = %0x", (int)read);

    return 0;
}
```

Making Measurements with the Counter

This section shows how to make a simple frequency measurement with the HP E1333 Universal Counter. The HP IBASIC example shows an interrupt driven model. Turbo C++ with the HP-IB drivers does not allow for interrupts.

HP IBASIC Version

```
10 CLEAR 80906.
20 OUTPUT 80906.;"*CLS;*RST"
30 Logical_addr = 48
40 Base_addr = DVAL("1FCC00";16)
50 COM Base_addr
60 CALL Reset
70 CALL Send_cmd(4,8)
71 !
72 !
80 REPEAT
90 UNTIL Comp = 0
91 !
92 !
100 CALL Read_data
110 STOP
111 !
112 !
120 SUB Read_status(Status, Rdy, Done, qrydry)
130 COM Base_addr
140 Status = READIO(-9826,Base_addr + 4)
150 Rdy = BIT(Status,0)
160 Done = BIT(Status,7) AND Rdy
170 Qrydry = BIT(Status,1)
180 SUBEND
181 !
182 !
190 SUB Wait_not_busy
200 COM Base_addr
210 REPEAT
220 CALL Read_status(Status,Rdy,Done,Qrydry)
230 UNTIL Rdy
240 SUBEND
241 !
250 SUB Wait_not_done
260 COM Base_addr
```

```

270 REPEAT
280 CALL Read_status(Status,Rdy,Done,Qrydry)
290 UNTIL Done
300 SUBEND
301 !
302 !
310 SUB Qrydry
320 COM Base_addr
330 REPEAT
340 CALL Read_status(Status,Rdy,Done,Qrydry)
350 UNTIL Qrydry
360 SUBEND
361 !
362 !
370 SUB Reset
380 COM Base_addr
390 WRITEIO -9826,Base_addr+8;15
400 CALL Wait_not_busy
410 WRITEIO -9826, Base_addr+10;0
420 WAIT 1
430 SUBEND
431 !
440 SUB Send_cmd(Cmd,Parm)
450 COM Base_addr
460 CALL Wait_not_busy
470 WRITEIO -9826,Base_addr+8;Cmd
480 CALL Wait_not_busy
490 WRITEIO -9826,Base_addr+10;Parm
500 SUBEND
501 !
502 !
510 SUB Read_data
520 COM Base_addr
530 INTEGER A(6)
540 CALL Send_cmd(14,0)
550 CALL Wait_not_done
560 FOR I = 1 TO 6
570 CALL Qrydry
580 A(I)=READIO(-9826,Base_addr+8)
590 A(I)=BINAND(A(I),255)

```

```

600 NEXT I
610 IF BIT(A(1),7) = 1 THEN
620 PRINT "overflow occurred, data not valid")
630 END IF
640 A(1) = BINAND(A(1),127)
650 M = (A(1)*2^32 + A(2)*2^24 + A(3)*2^16 + A(4)*2^8 + A(5))*2^(A(6)-128)
660 PRINT "Measured value = ";M
670 SUBEND

```

Embedded Controller Example Programs

This section shows example programs for the HP E1480A V/360 embedded Model 360-based VXI controller. These programs make a frequency measurement on channel 1 using the programming procedure previously discussed. Two programming versions are provided; one written in HP BASIC/UX and another written in C programming language.

System Configuration

Mainframe: HP 75000 Series C (HP E1401B)

Controller: HP V/360 (HP E1480A) w/Resource Manager and Slot 0

Programming Language: HP BASIC/UX, C

Universal Counter: HP E1333A (Logical Address = 48)

HP BASIC/UX Version

```

10 !Compute the base address of the E1333A at a logical address of 48.
20 Logical_address=48
30 Base_address=(Logical_address*64)+49152
40 !Map the A16 address space for READIO/WRITEIO calls on the HP V/360.
50 CONTROL 16,25;2
60 COM Base_address
70 !Reset the counter.
80 CALL Send_cmd(15,0)
90 !Call the interrupt service routine when an interrupt occurs.
100 ON INTR 16 GOSUB Int_service
110 !Enable VME interrupts on the HP V/360.
120 ENABLE INTR 16;2
130 !Set the function and gate time (Frequency and gate time = 1024 msec).
140 CALL Send_cmd(4,9)
150 !Computer can perform other tasks until interrupt occurs.
160 FOR I=1 TO 1000
170 DISP I
180 NEXT I
190 !The interrupt service routing performs three tasks:
200 ! 1. Ensure the device interrupting has logical address 48 (HP E1333A).
210 ! 2. Ensure status returned indicates HP E1333A has a response ready.
220 ! 3. Read the Interrupt Vector register to check that frequency

```

```

230 !measurement is complete.
240 Int_service:STATUS 16,4;Stat4    !V/360 interrupt reason.
250   STATUS 16,6;Stat6    !VXI device interrupt acknowledge value.
260   IF Stat42 THEN STOP
270   Intr_address=BINAND(Stat6,255)
280   IF Intr_addressLogical_address THEN STOP
290   Status_register=BINAND(BINAND(SHIFT(Stat6,8),255),255)
300   IF Status_register<134 THEN STOP

310   !Check the interrupt vector
320   REPEAT
330     Int_vector=READIO(-16,Base_address+14)
340     Vector=BINAND(SHIFT(Int_vector,8),15)
350     SELECT "FREQUENCY"
360     CASE ="FREQUENCY"
370       Meas_ready=BIT(Vector,0)
380     CASE ="PERIOD"
390       Meas_ready=BIT(Vector,1)
400     CASE ="RATIO"
410       Meas_ready=BIT(Vector,2)
420     CASE ="TINT"
430       Meas_ready=BIT(Vector,3)
440     END SELECT
450     UNTIL Meas_ready=0
460     !

470   !Call the subprogram to read, convert and print out the result.
480   CALL Read_data
490   END

500   !This subprogram reads the status register of the device and returns
510   !the operational status bits.
520   SUB Read_status(Status,Rdy,Done,Qryrdy)
530     Read_status: !
540     COM Base_address
550     Status=READIO(-16,Base_address+4)
560     Rdy=BIT(Status,0)
570     Done=BIT(Status,7) AND Rdy
580     Qryrdy=BIT(Status,1) AND Done
590   SUBEND

600   !This subprogram calls Read_status subprogram to check status bit 0
610   !(RDY) to determine when a command or parameter can be sent.
620   SUB Wait_not_bsy
630     COM Base_address
640     REPEAT
650       CALL Read_status(Status,Rdy,Done,Qryrdy)
660     UNTIL Rdy
670   SUBEND

680   !This subprogram calls Read_status to check validity of status bit 7
690   !(DONE). This ensures the validity of status bit 1.

700   SUB Wait_done
710     COM Base_address
720     REPEAT
730       CALL Read_status(Status,Rdy,Done,Qryrdy)
740     UNTIL Done
750   SUBEND

```

```

760 !This subprogram call Read_status to check status bit 1 to determine
770 !when the response register contains data.
780 SUB Qry_ready
790   COM Base_address
800   REPEAT
810     CALL Read_status(Status,Rdy,Done,Qryrdy)
820   UNTIL Qryrdy
830 SUBEND

840 !This subprogram writes commands and parameters to the Command
850 !and Parameter registers. The state of the HP E1333A is checked
860 !before either write to prevent sending commands/parameters before
870 !the device is ready for them.
880 SUB Send_cmd(Cmd,OPTIONAL INTEGER Parm)
890   COM Base_address
900   CALL Wait_done
910   WRITEIO -16,Base_address+8;Cmd
920   IF NPAR1 THEN
930     CALL Wait_not_bsy
940     WRITEIO -16,Base_address+10;Parm
950   END IF
960   CALL Wait_done
970 SUBEND

980 !This subroutine retrieves the data, converts it and prints out the
990 !reading.
1000 SUB Read_data
1010   COM Base_address
1020   INTEGER A(6)
1030   CALL Send_cmd(14,0)
1040   CALL Qry_ready
1050   FOR I=1 TO 6
1060     A(I)=READIO(-16,Base_address+8)
1070     A(I)=BINAND(A(I),255)
1080   NEXT I

1090 !Check for overflow
1100 IF BIT(A(1),7)=1 THEN
1110   PRINT "OVERFLOW OCCURRED - DATA INVALID"
1120 END IF
1130 A(1)=BINAND(A(1),127)
1140 M=(A(1)*2^32+A(2)*2^24+A(3)*2^16+A(4)*2^8+A(5)
*2^(A(6)-128)
1150 PRINT "MEASURED FREQUENCY:",M,"Hz."
1160 SUBEND

```

C Version

```
/* **** */
*   C Program for frequency measurements using HP E1333A Counter   *
/* **** */

#include <stdio.h>
#include <fcntl.h>
#include "sys/vxi.h" /* source file for HP V/360 VXI drivers */

#define logical_address 48 /* Logical Address of HP E1333A */
/* Initialize interrupt flag */
int i_flag =0;

typedef unsigned short word;
typedef struct device_registers {
    word id_register;
    word devtype_register;
    word statuscontrol_register;
    word reserved_register;
    word cmdresponse_register;
    word parameter_register;
    word reserved2_register;
    word ivector_register;
} DEVICE_REGISTERS;

/* Function to reset the HP E1333A counter */
void reset_dac33A(d33A_ptr)
DEVICE_REGISTERS *d33A_ptr;
{
    int l;

    /* send reset command 15 to command register */
    d33A_ptr->cmdresponse_register = 15;

    /* wait for READY bit to become valid */
    while(((d33A_ptr->statuscontrol_register)&1) == 0);

    /* send parameter to begin reset activity */
    d33A_ptr->parameter_register = 0;

    /* Wait a few microseconds to allow reset activity to complete */
    for(l=0;l<10;l++){}

    /* Function to send commands and parameter to HP E1333A counter */
    void dac33A_send(d33A_ptr,command,parameter)
    DEVICE_REGISTERS *d33A_ptr;
    int command, parameter; {

        /* wait for READY bit to become valid */
        while(((d33A_ptr->statuscontrol_register)&1)==0);

        /* send the command to the command register */
        d33A_ptr->cmdresponse_register = command;

        /* wait for the READY bit to become valid */
        while(((d33A_ptr->statuscontrol_register)&1) == 0);

        /* send the parameter to the parameter register */
        d33A_ptr->parameter_register = parameter;
    }

    /* Function to retrieve and convert the counter reading */
    float d33A_read(d33A_ptr,command,channel)
    DEVICE_REGISTERS * d33A_ptr;
    {
```

```

float result, r_exp = 1;
int k;
unsigned short data_word;

/* wait for DONE, QUERY RESP and READY bits to become valid */
while(((d33A_ptr- statuscontrol_register)&0x83) != 0x83);

/* get the first byte of data */
data_word = ((d33A_ptr- cmdresponse_register)&0xff);

/* check for overflow */
if((data_word&1)==1)
{   printf("\n\nOVERFLOW OCCURRED - DATA INVALID\n");
    exit(0);
}

/* place first byte in the result variable */
result = data_word >> 32;

/* wait for QUERY RESP REGISTER READY bit to become valid */
while(((d33A_ptr- statuscontrol_register)&2) == 0) ;

/* get second byte of data */
data_word = ((d33A_ptr- cmdresponse_register)&0xff);
result = result + (data_word >> 24);

/* wait for QUERY RESP REGISTER READY bit to become valid */
while(((d33A_ptr- statuscontrol_register)&2) == 0);

/* get third byte of data */
data_word = ((d33A_ptr- cmdresponse_register)&0xff);
result = result + (data_word >> 16);

/* wait for QUERY RESP REGISTER READY bit to become valid */
while(((d33A_ptr- statuscontrol_register)&2) == 0);

/* get fourth byte of data */
data_word = ((d33A_ptr- cmdresponse_register)&0xff);
result = result + (data_word >> 8);

/* wait for QUERY RESP REGISTER READY bit to become valid */
while(((d33A_ptr- statuscontrol_register)&2) == 0);

/* get fifth byte of data */
data_word = ((d33A_ptr- cmdresponse_register)&0xff);
result = result + data_word;

/* wait for QUERY RESP REGISTER READY bit to become valid */
while(((d33A_ptr- statuscontrol_register)&2) == 0);

/* get sixth byte of data */
data_word = ((d33A_ptr- cmdresponse_register)&0xff);

/* convert sixth byte, the exponent */
for (k = data_word-128; k; k + + )
{
    r_exp = r_exp/2;
}
result = result * r_exp;
return result;
}

/* Interrupt handler routine */
int handler(eid,causevec)
int eid;

```

```

struct interrupt_struct *causevec;
{
/* set the interrupt flag to alert main program that counter has reading */
i_flag = 1;

/* ensure the correct interrupt has occurred */
if ((causevec- mask&0xffff) != 0xfe30)
{
printf("\n\nReceived incorrect interrupt vector\n");
printf("Expected interrupt from E1333A at logical address 48\n");
printf("\n Received interrupt vector: %x HEX\n",causevec- mask&0xffff);
printf(" Expecting: fe30 HEX \n");
printf(" fe HEX— frequency complete\n");
printf(" 30 HEX— logical address of 48\n");
exit(0);
}
}

main()
{
int eid;
DEVICE_REGISTERS *dev;
int i; struct interrupt_struct causevec;
float reading;

/* Open the HP V/360 VXI interface */
eid = open("/dev/vxti/primary",O_RDWR);
if(eid){
perror("open");
exit(1);
}

/* Mask for VME interrupts */
causevec.cause = 0x2;

/* Set up interrupt handler for interrupting device */
io_on_interrupt(eid,&causevec,handler);

/* Enable interrupts on the VXI interface */
io_interrupt_ctl(eid,1);

/* Retrieve the pointer for the A16 registers of the device */
dev=(DEVICE_REGISTERS*)vxi_get_a16_addr(eid,logical address);

/* Call the function to reset the counter */
reset_dac33A(dev);

/* Set the function: Frequency with 1024 msec gate time */
dac33A_send(dev,4,9);

/* Let computer perform some other task while waiting for interrupt */
for (i = 0;i + + )
{
printf("\r%i",i);
/* check interrupt flag and if set, end looping */
if (i_flag == 1)
{ i=4000; }
}

/* Send the command to read the result */
dac33A_send(dev, 14,0);

```



```
/* Call the function to retrieve and convert the reading */  
reading = d33A_read(dev,14,0);  
/* Print out the measured frequency */  
printf("\nFrequency is %.1f \n",reading);  
}
```

Appendix C

HP E1333A Universal Counter Error Messages

Table C-1 lists the error messages associated with the HP E1333A 3-Channel Universal Counter module programmed by SCPI. See the appropriate mainframe or command module manual for a complete list of error messages.

Table C-1. 3-Channel Universal Counter Error Messages

Code	Message	Potential Cause(s)
-211	Trigger ignored	Trigger occurred while the instrument is in the idle state, trigger occurred from a source not specified, or trigger too fast.
-214	Trigger deadlock	The Counter is triggered from another source (e.g. READ?) after the trigger source has been set to TRIG:SOUR BUS.
-221	Settings conflict	Counter parameters are set such that a measurement cannot be made.
-222	Data out of range	The parameter value specified is too large or too small.
-230	Data corrupt or stale	Data retrieved from memory is possibly invalid.
-231	Data questionable	Measurement data is possibly invalid.
-240	Hardware error	Hardware error detected during power-up cycle.
-314	Save/recall memory lost	Configuration retrieved from specified location in memory is invalid or missing. A valid save must be performed at the specified location before retrieving data.
-330	Self-test failure	Error detected during self test.
2001	Invalid channel number	Channel specified does not contain the requested feature.

- *CLS, 98, 101
- *ESE, 95, 101
- *ESE?, 101
- *ESR?, 101
- *IDN?, 101
- *OPC, 101
- *OPC?, 101
- *RCL, 101
- *RST, 20, 38, 101, 103
- *SAV, 101
- *SRE, 101
- *SRE?, 101
- *STB, 95
- *STB?, 101
- *TRG, 101, 103
- *TST?, 101, 103
- *WAI, 101

A

- A16 Address Space, 108, 110
- Abbreviated Commands, 58
- ABORt Command, 46, 60
- About Register-Based Programming, 107
- AC Coupling, 23, 75
- Address
 - base, 108, 110
 - LADDR, 16
 - logical, 16, 108
 - space (A16), 108, 110
 - switch, setting, 16
- Addressing Registers, 107, 111
- Aperture Time
 - channel selection, 87
 - description, 48
 - frequency measurement, 87
 - selecting, 47, 88
 - setting, 48
 - verses resolution, 88
 - versus resolution, 48

- Attenuation
 - default, 20
 - description, 23, 40
 - input, 74
 - setting, 23, 40

B

- Base Address, 108, 110
- BASIC Program Examples
 - frequency measurements, 129 - 131
 - reading the registers, 127
 - resetting the counter, 125
- BASIC/UX Program Example, 131 - 133
- Block Diagram, 12
- Boolean Command Parameters, 59

C

- C Program Examples
 - frequency measurements, 134 - 137
 - reading the registers, 128
 - resetting the counter, 125
- Cables
 - connecting, 15
 - shielded, 30
- Cautions, 15
- Certification, 5
- Changing Priority Interrupt Jumpers, 17
- Channel
 - descriptions, 13
 - implied, 58
 - input characteristics, 13
 - input terminal, 13
 - measurement functions, 11
 - monitoring, 70 - 71
 - reading a single, 120
 - trigger level, 86
- Checking
 - for errors, 53, 98
 - for overflow, 54, 122
- *CLS, 98, 101
- Command Parameter Register, 114
- Command Reference, 57 - 104
- Command/Response Register, 113

Commands

- abbreviated, 58
- common (*) quick reference, 103
- IEEE 488.2, 57, 101
- implied, 58
- implied channel, 58
- keyword, 58
- linking, 59
- measurement, 43
- optional, 58
- optional parameters, 59
- parameters, 59
- query parameters, 59
- quick reference, 102
- registers, 113
- SCPI, 57
- SCPI format, 57
- SCPI quick reference, 102
- separator, 58
- summary (register-based), 115 - 120
- types, 57

Comment sheet, reader, 9

Common (*) Commands, 57, 101

- *CLS, 98, 101
- *ESE, 95, 101
- *ESE?, 101
- *ESR?, 101
- format, 57
- *IDN?, 101
- *OPC, 101
- *OPC?, 101
- parameters, 57
- quick reference, 103
- *RCL, 101
- *RST, 20, 38, 101, 103
- *SAV, 101
- *SRE, 101
- *SRE?, 101
- *STB, 95
- *STB?, 101
- *TRG, 101, 103
- *TST?, 101, 103
- *WAI, 101

Composite Video Waveform, 32

Condition Register, 96

CONFigure Subsystem, 44, 61 - 68

CONFigure:FREQuency, 62

CONFigure:NWIDth, 63

CONFigure:PERiod, 64

CONFigure:PWIDth, 65

CONFigure:RATio, 66

CONFigure:TINTerval, 67

CONFigure:TOTALize, 68

CONFigure? Command, 69

Configuring the Universal Counter, 15 - 18, 37

Conformity, declaration, 7

Connecting Field Cables, 15

Constraints, input signal, 21

Control Register, 112

Counting Events, 25 - 26

Coupling

- AC, 23, 75
- DC, 24, 75
- default, 20
- input, 23 - 24, 40, 75
- setting, 23, 40, 75

D

DC Coupling, 24, 75

Declaration of conformity, 7

Default Conditions, 20

Definition of Instrument, 13

Description, 11

Device Type Register, 112, 127 - 128

- reading, 127 - 128

Discrete Command Parameters, 59

DISPlay Subsystem, 70 - 71

DISPlay:MONitor:CHANnel, 70

DISPlay:MONitor:CHANnel?, 70

DISPlay:MONitor[:STATe], 71

DISPlay:MONitor[:STATe]?, 71

Documentation history, 6

E

Embedded Controller Example Programs, 131 - 137

Enable Register, 97

Errors

- checking for, 53
- messages, 139 - 140
- numbers, 139 - 140
- query for, 98
- queue, 98
- self test (*TST?), 103

*ESE, 95, 101

*ESE?, 101

*ESR?, 101

Event Level

- channel 1, 115
- channel 2, 115
- default, 20
- description, 22, 41
- query, 86
- setting, 22, 41, 86, 115

Event Register, 96 - 97

Event Slope
default, 20
description, 23, 41
query, 87
setting, 23, 41, 87

F

FETCh? Command, 45 - 46, 72

Format

common commands, 57
SCPI commands, 57

Frequency Measurement, 27 - 28

aperture time, 87
configuring for, 62
overflow indication, 62, 79
performing, 116
range, 62, 78
resolution, 62, 78
SCPI commands, 43
signals measured, 62, 78

Frequency Range

default, 20
query, 69

Frequency Resolution

default, 20

Front Panel, 15

G

Gate Time, 48, 88

Getting Started, 11 - 14

I

*IDN?, 101

IEEE 488.2 Commands

quick reference, 103

Impedance

default, 20
input, 76
setting, 24, 40, 76

Implied

channel, 58
commands, 58

INITiate Command, 45, 73

Input

attenuation, 23, 40, 74
channel characteristics, 13
coupling, 23 - 24, 40, 75
default, 20
impedance, 24, 40, 76
low-pass filter, 24, 40, 75

maximum voltage/power allowed, 13, 15, 21
parameters, selecting, 40
signal conditioning, 22, 40, 115
signal constraints, 21
source, 13
terminal, 13

INPut Subsystem, 74 - 76

INPut:ATTenuation, 74

INPut:ATTenuation?, 75

INPut:COUPling, 75

INPut:COUPling?, 75

INPut:FILTer[:LPAss][:STATe], 75

INPut:FILTer[:LPAss][:STATe]?, 76

INPut:IMPedance, 76

INPut:IMPedance?, 76

Instrument Definition, 13

Interrupt

acknowledge line (IACK*), 114
checking for overflow using, 55
handler, 114
line, 17
priority, 17
requests, 114
vector register, 114

IRQ Jumpers, 17, 114

K

Keywords

description, 14
rules for use, 58

L

LADDR, 16

Linking Commands, 59

Logical Address, 16

changing, 16
factory setting, 16, 108
switch, setting, 16

Low-pass Filter

default, 20
description, 24, 40
enable/disable, 75
setting, 24, 40

M

Making Measurements, 129 - 137

Manufacturer ID Register, 111, 127 - 128

reading, 127 - 128

MEASure Subsystem, 44, 77 - 83

MEASure:FREQuency?, 78

MEASure:NWIDth?, 79
MEASure:PERiod?, 80
MEASure:PWIDth?, 81
MEASure:RATio?, 82
MEASure:TINterval?, 83
Measurement
 channel functions, 11
 commands, 43
 examples, 24
 frequency, 27 - 28, 116
 functions, 42, 89
 initiating, 73, 84
 period average, 31, 64, 80, 116
 procedure, 21, 39
 pulse width, 32 - 33
 range, 46
 ratio, 29 - 30, 66, 82, 118
 resolution, 46
 retrieve from memory, 72
 stopping, 46
 time interval, 34 - 35, 67, 83, 116
 totalize, 68
Multiple SCPI Commands, linking, 59

N

Negative Pulse Width
 channel selection, 63, 79
 configuring for, 63, 79
 edge select, 63, 79
 overflow indication, 63, 79
 range, 63, 79
 resolution, 63, 79
Number of Periods
 description, 49
 selecting, 47
 setting, 49
 versus resolution, 49, 91
Numeric Command Parameters, 59

O

*OPC, 101
*OPC?, 101
Optional
 command parameters, 59
 commands, 58
Overflow, checking for, 54 - 55, 122

P

Parameters
 register, 114
 SCPI commands, 59
 selecting for input, 40
Period Average Measurement, 31
 channel selection, 64, 80, 91
 configuring for, 64, 80
 enter number of periods, 91
 overflow indication, 64, 80
 performing, 116
 range, 64, 80
 ratio measurement, 92
 resolution, 64, 80
 selecting number of periods, 91
 signals measured, 64, 80
 time interval, 93
Positive Pulse Width
 channel selection, 65, 81
 configuring for, 65, 81
 edge select, 65, 81
 overflow indication, 65, 81
 range, 65, 81
 resolution, 65, 81
Program Examples
 counting events, 25 - 26
 frequency measurement, 27 - 28
 making measurements, 129 - 137
 period average measurement, 31
 pulse width measurement, 32 - 33
 ratio measurement, 29 - 30
 reading the registers, 127 - 128
 register-based, 125 - 137
 time interval measurement, 34 - 35
Programming
 examples, register based, 125 - 137
 procedure, 120 - 123
 register-based, 107 - 138
 the universal counter, 14
Pulse Width Measurement, 32 - 33
 negative, 63, 79
 positive, 65, 81

Q

Query

- aperture time, 88
- command parameters, 59
- errors, 98
- event level setting, 86
- event slope setting, 87
- function, 69
- input attenuation, 75
- input coupling, 75
- input impedance, 76
- low-pass filter state, 76
- measurement function, 90
- monitor mode channel, 70
- monitor mode state, 71
- number of periods, 92 - 94
- range, 69
- response register, 113
- SCPI commands, 56
- trigger level setting, 86
- trigger source, 100

Questionable Data/Signal Register, 95

Quick Reference

- IEEE 488.2 common commands, 103
- SCPI commands, 102

R

Range

- default, 20
- description, 46
- query, 69
- selecting, 46
- setting, 47, 61, 77

Ratio Measurement, 29 - 30

- channel selection, 66, 82
- configuring for, 66, 82
- number of periods, 92
- overflow indication, 66, 82
- performing, 118
- range, 66, 82
- resolution, 66, 82
- signals measured, 66, 82

*RCL, 101

READ Registers, 111

- device type, 112, 127 - 128
- interrupt vector, 114
- manufacturer ID, 111, 127 - 128
- response, 113
- status, 112, 127 - 128

READ? Command, 45 - 46, 84

Reader comment sheet, 9

Register-Based Programming, 107 - 138

- addressing the registers, 107
- base address, 108
- command list, 113
- command summary, 115 - 120
- computing the answer, 122 - 123
- description, 107
- interrupt requests, 114
- programming examples, 125 - 137
- programming flowchart, 124
- register definitions, 111
- register descriptions, 111
- register offset, 109
- register programming procedure, 120 - 123

Registers

- addressable, 111
- addressing, 107, 111
- command list, 113
- command parameter, 114
- command/response, 113
- condition, 96
- control/status, 112
- definitions, 111
- descriptions, 111
- device type, 112, 127 - 128
- enable, 97
- event, 96 - 97
- interrupt vector, 114
- manufacturer ID, 111, 127 - 128
- offset, 109
- parameter, 114
- programming examples, 125 - 137
- programming flowchart, 124
- programming procedure, 120 - 123
- query response, 113
- questionable data/signal, 95
- READ, 111
- reading, 127 - 128
- response/command, 113
- standard event status, 95
- standard/operational status, 95
- status, 127 - 128
- status byte, 95
- status/control, 112
- WRITE, 111

Reset Default Conditions, 20, 38

Resetting the Counter, 120

- example program, 125 - 126

- Resolution
 - default, 20
 - description, 47
 - selecting, 46
 - setting, 47, 61, 77
 - versus aperture time, 48, 88
 - versus number of periods, 49, 91
- Response/Command Register, 113
- *RST, 20, 38, 101, 103

S

- Safety warnings, 6, 15
- *SAV, 101
- Schematic, simplified, 12
- SCPI Commands, 38, 57, 102
 - abbreviated, 58
 - ABORt, 46, 60
 - CONFigure subsystem, 44, 61 - 68
 - CONFigure?, 69
 - DISPlay subsystem, 70 - 71
 - FETCh?, 45 - 46, 72
 - format used, 57
 - implied, 58
 - INITiate, 45, 73
 - INPut subsystem, 74 - 76
 - keyword description, 14
 - linking, 59
 - long form, 58
 - MEASure subsystem, 44, 77 - 83
 - optional, 58
 - optional parameters, 59
 - parameters, 59
 - query parameters, 59
 - querying the counter, 56
 - quick reference, 102
 - READ?, 45 - 46, 84
 - reference, 60
 - selecting, 14
 - SENSe: subsystem, 85 - 94
 - short form, 58
 - STATus subsystem, 95 - 97
 - SYSTem subsystem, 98
 - TRIGger subsystem, 99 - 100
- Selecting
 - aperture time, 47, 88
 - input parameters, 40
 - number of periods, 47
 - range, 46
 - resolution, 46
 - SCPI Commands, 14
 - trigger source, 50, 100

- Self Test Errors, 103
- SENSe: Subsystem, 85 - 94
- SENSe:EVENT:LEVel, 86
- SENSe:EVENT:LEVel?, 86
- SENSe:EVENT:SLOPe, 87
- SENSe:EVENT:SLOPe?, 87
- SENSe:FREQuency:APERture, 87
- SENSe:FREQuency:APERture?, 88
- SENSe:FUNCTion, 44 - 45, 89
 - :FREQuency, 89
 - :NWIDth, 89
 - :PERiod, 89
 - :PWIDth, 89
 - :RATio, 89
 - :TINTerval, 89
 - :TOTalize, 89
- SENSe:FUNCTion?, 90
- SENSe:PERiod:NPERiods, 91
- SENSe:PERiod:NPERiods?, 92
- SENSe:RATio:NPERiods, 92
- SENSe:RATio:NPERiods?, 93
- SENSe:TINTerval:NPERiods, 93
- SENSe:TINTerval:NPERiods?, 94
- Setting
 - address switch, 16
 - aperture time, 48
 - event level, 22, 41, 86, 115
 - event slope, 23, 41, 87
 - input attenuation, 23
 - input coupling, 23, 40, 75
 - input impedance, 24, 40, 76
 - input low-pass filter, 24, 40
 - input signal conditioning, 22, 40, 115
 - number of periods, 49
 - range, 47, 61, 77
 - resolution, 47, 61, 77
- Shielded Cables, 30
- Specifications, 105 - 106
- Speed
 - increasing throughput, 107
 - measurement cycle, 47
- *SRE, 101
- *SRE?, 101
- Standard Commands for Programmable Instruments
 - See SCPI Commands
- Standard Event Status Register, 53, 95
- Standard/Operational Status Register, 95
- Static Electricity, 15
- Status Byte Register, 95
- Status Register, 127 - 128
 - reading, 127 - 128
- STATus Subsystem, 95 - 97
- Status/Control Register, 112

STATus:QUEStionable, 96
STATus:QUEStionable:CONDition?, 96
STATus:QUEStionable:ENABle, 96
STATus:QUEStionable:ENABle?, 97
STATus:QUEStionable[:EVENT]?, 97
*STB, 95
*STB?, 101
Stopping a Measurement, 46
Switch, logical address, 16
Synchronizing Instruments, 52
SYSTem Subsystem, 98
SYSTem:ERRor?, 98

T

Time Interval Measurement, 34 - 35
 channel selection, 67, 83
 configuring for, 67, 83
 number of periods, 93
 overflow indication, 67, 83
 performing, 116
 range, 67, 83
 resolution, 67, 83
 start and stop edges, 67, 83
Totalize Measurement
 configuring for, 68
 continuous counting, 68
 overflow indication, 68
 range, 68
 reading measurement results, 68
 resolution, 68
 timing, 68
Totalizing Events, 25, 117
*TRG, 101, 103
Trigger Source
 default, 20
 SCPI commands, 51, 99 - 100
 selecting, 50
TRIGger Subsystem, 99 - 100
Trigger System Commands, 51, 99 - 100
TRIGger:SOURce, 51, 99
 BUS, 51, 99
 HOLD, 51, 99
 IMMediate, 51, 99
TRIGger:SOURce?, 100
TRIGger[:IMMediate], 51, 99
*TST?, 101, 103

U

Understanding the Universal Counter, 37 - 56
Universal Counter
 block diagram, 12
 command reference, 57 - 104
 command summary, 115 - 120
 configuring, 16, 37
 default conditions, 20
 description, 11
 error messages, 139
 front panel, 15
 making measurements, 129 - 137
 programming of, 14
 query SCPI commands, 56
 reading a single channel, 120
 reading the status, 118 - 119
 register-based programming, 107 - 138
 resetting, 120, 125 - 126
 specifications, 105 - 106
 understanding the, 37 - 56
 using the, 19 - 36
Using the Universal Counter, 19 - 36

V

Voltage
 maximum allowed, 13, 15, 21
VXIbus
 access directly, 107
 interrupt lines, 17

W

*WAI, 101
WARNINGS, 6, 15
Warranty, 5
WRITE Registers, 111
 command, 113
 command parameter, 114
 control, 112

Notes
